

Instruction Sheet #51-1012
Replaces Instruction Sheet #400

S&S Cycle, Inc.

14025 County Hwy. G P.O. Box 215
Viola, Wisconsin 54664 U.S.A.
Phone 608-627-1497 Fax 608-627-1488



Revised 6-19-01

Copyright ©, 2001
by S&S Cycle, Inc.

All rights reserved. Printed in the U.S.A.

Customer Service Email - sscust@sscycycle.com
Technical Assistance Email - sstech@sscycycle.com

Installation and Jetting Instructions for S&S Super E and G Series "Shorty" Carburetors

SAFE INSTALLATION AND OPERATION RULES:

Before installing your S&S carburetor, it is your responsibility to read and follow the installation and maintenance procedures in these instructions and to follow the basic rules below for your personal safety.

- Gasoline is extremely flammable, explosive under certain conditions, and the fumes toxic when inhaled. Do not smoke around gasoline. Perform the installation in a well-ventilated area away from open flames or sparks.
- Compressed air and particles dislodged by compressed air are potentially harmful to eyes and body. Wear protective goggles when using compressed air and always direct the air stream away from yourself and others nearby.
- Some solvents, degreasers and other chemicals are harmful, especially to skin and eyes. Many chemical compounds such as lacquer thinner are also flammable and present a fire hazard. Read the manufacturer's instruction label for precautions and proper use. Use in a well ventilated area and wear protective clothing to avoid personal injury.
- If the motorcycle has been running, wait until the engine and exhaust pipes have cooled before performing any installation steps to avoid getting burned.
- Before performing any installation steps, disconnect and remove the battery to eliminate potential sparks and inadvertent engagement of the starter while working on the motorcycle.
- Read instructions thoroughly and carefully so all procedures are completely understood before performing any installation steps.
- Consult an authorized H-D service manual for correct disassembly, reassembly, and installation procedures for any parts that need to be removed to facilitate the installation.
- Use good judgment during assembly, installation, and when operating the motorcycle. Good judgment begins with a clear head. Don't let alcohol, drugs, or fatigue impair judgment. Perform the assembly and installation when fresh.
- For optimum performance and safety and to minimize potential damage to the carburetor or other components, use correct hardware and follow procedures outlined in S&S instructions and an authorized H-D service manual.
- Be sure all fuel lines are routed correctly with clamps in place and tightened. Lines must not contact exhaust pipes or other extremely hot surfaces where they could melt or leak and catch fire.
- Motorcycle exhaust fumes are toxic and must not be inhaled. Run motorcycle only in a well ventilated area where fumes can dissipate.
- S&S products often offer substantially more power than the stock items they replace. It is the sole and exclusive responsibility of the user to determine the suitability of the product for his or her use. The user shall assume all legal, personal injury risk and liability and all other obligations, duties and risks associated therewith. **S&S parts are intended for the very experienced rider only.**

Important Notice:

Statements in this instruction sheet preceded by the following words are of special significance:

WARNING

Means there is the possibility of injury to yourself or others.

CAUTION

Means there is the possibility of damage to the motorcycle or a component.

NOTE

Other information of particular importance has been placed in italic type.

S&S urges you to take special notice of these advisories.

WARRANTY:

All S&S parts are guaranteed to the original purchaser to be free of manufacturing defects in materials and workmanship for a period of six (6) months from the date of purchase. Merchandise that fails to conform to these conditions will be repaired or replaced at S&S's option if the parts are returned to S&S by the purchaser within the 6 month warranty period or within 10 days thereafter.

In the event warranty service is required, the original purchaser must notify S&S of the problem immediately. Some problems can be rectified by a telephone call and need no further action. A part that is suspected of being defective must not be replaced without prior authorization from S&S. If it is deemed necessary for S&S to make an evaluation to determine whether the part was defective, it must be packaged properly to avoid further damage, and be returned prepaid to S&S with a copy of the original invoice of purchase and a detailed letter outlining the nature of the problem, how the part was used, and the circumstances at the time of failure. If, after an evaluation was made by S&S, the part was found to be defective, repair, replacement, or refund will be granted.

ADDITIONAL WARRANTY PROVISIONS:

- (1) No part shall be returned to S&S without first contacting the company and obtaining a Return Authorization (RA) number.
- (2) S&S shall have no obligation in the event an S&S part is modified by any other person or organization, or if another manufacturer's part is substituted for one provided by S&S.
- (3) S&S shall have no obligation if an S&S part becomes defective in whole or in part as a result of improper installation, improper break-in or maintenance, improper use, abnormal operation, or any other misuse or mistreatment.
- (4) S&S shall not be liable for any consequential or incidental damages resulting from the failure of an S&S part, the breach of any warranties, the failure to deliver, delay in delivery, delivery in non-conforming condition, or for any other breach of contract or duty between S&S and a customer.
- (5) S&S parts are designed exclusively for use on Harley-Davidson and other American V-Twin motorcycles. S&S shall have no warranty or liability obligation if an S&S part is used in any other application.

Introduction

S&S Super E and G Shorty carburetors are designed for Harley-Davidson Big Twin and Sportster engines as well as other American V-Twin engines. They are butterfly type carburetors with fully adjustable idle mixture and changeable mid range and high speed jets. Both carburetors also feature an adjustable accelerator pump and variable enrichment/fast idle device for improved throttle response, engine starting and warm ups.

The Super E has a 1 $\frac{1}{8}$ " (47.6mm) bore and 1 $\frac{1}{16}$ " (39.6mm) venturi. It is identified by an "E" cast into the throttle linkage side of the body below the letters "S&S SUPER". The Super E is recommended for use on any displacement Big Twin or Sportster.

NOTE - Because S&S carburetors are significantly larger than OEM units, unmodified, small displacement engines such as 883 and Iron Head Sportsters may experience sluggish low speed response when equipped with S&S carburetors. This can often be minimized with careful tuning.

The Super G has a 2 $\frac{1}{16}$ " (52.3mm) bore and 1 $\frac{3}{4}$ " (44.5mm) venturi. It is identified by a "G" cast into the carb body (**See Picture 1**). The Super G is recommended for use on modified engines of 74 cubic inches or more. While both carburetors can be made to work on most engines, the Super G is not recommended for small, low compression engines. If there is doubt as to which carburetor to use, S&S suggests the Super E.

IMPORTANT NOTE - Recommended for Racing Only.

S&S carburetors are not legal for use in California on motor vehicles operated on public highways or in other states where similar pollution laws apply. The user shall determine the suitability of the product for his or her use and shall assume all risk and liability in connection therewith.

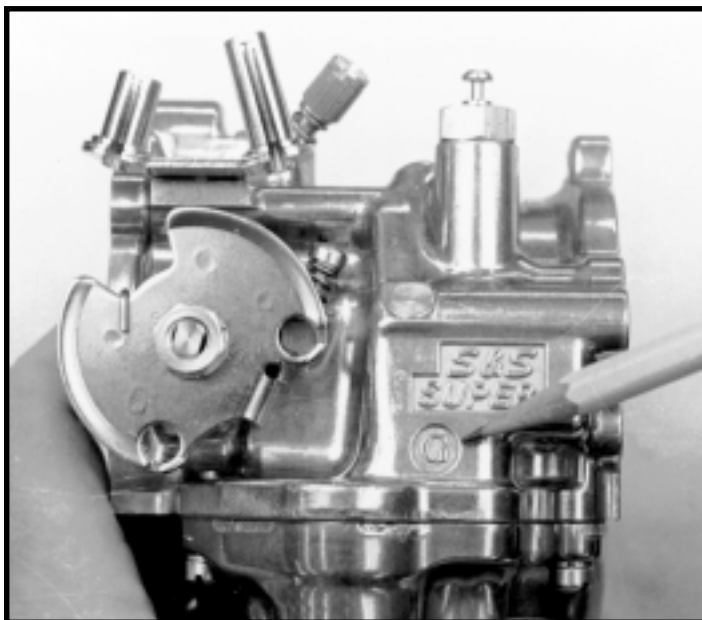

Picture 1

Kit Contents:

- Each complete carb kit includes:
- One S&S Super E or Super G gas carburetor
- One S&S teardrop air cleaner assembly
- One manifold
- Mounting hardware
- Fuel line, fuel line insulator, clamps and overflow line
- One extra intermediate jet and two main jets
- VOES tubing and additional hardware (when applicable)
- Installation and jetting instructions

Chrome Plating the Carburetor

NOTE - S&S does not recommend chrome plating the Super E or G carburetor. Preparation requires polishing with abrasive buffing compounds. These materials invariably plug air and/or fuel passages and other orifices regardless of precautions taken.

CAUTION - The chrome plating process can alter critical operating tolerances in several areas. Additionally, chrome may obstruct fuel passages, possibly altering the fuel mixture and causing engine damage. All manufacturer warranties become void if any part of the carburetor is polished, chrome plated or otherwise altered.

Throttle Requirements

NOTE - S&S Super E and G carburetors require the use of a two cable, pull open - pull closed throttle assembly. All 1980 and earlier stock H-D models equipped with a single cable throttle mechanism must be converted to the two cable, pull open-pull closed type. S&S offers these throttle assemblies but does not include them with any carburetor kit because of the multitude of chassis designs and fitment requirements.

WARNING - Single, braided wire cable throttle mechanisms cannot mechanically close the throttle. If throttle inadvertently sticks in open position, loss of control of motorcycle and personal injury to operator or others may result.

1980 and Earlier Motorcycles

All stock chassis 1980 and earlier, or any motorcycle equipped with single cable throttle system must be converted to a two cable system. Throttle assembly kits may be ordered separately. See descriptions below.

1981 to Present Big Twin Models

Stock Big Twin models from 1981 to 1989 have two cable throttle system designed for stock, butterfly type carburetors. Big Twins from 1990 to present have a two cable throttle system designed for the stock, constant velocity (CV) type carburetor. In spite of the differences in throttle cables for these year groups, stock throttle cables on all 1981 to present Big Twin models can be installed on the S&S Super E or G



Picture 2

throttle linkage with no cable modification. S&S Super E and G carb kits for 1936 to 1989 Big Twins contain a throttle cable guide (11-2339) designed for butterfly type throttle cables, and kits for 1990 and later Big Twins contain a taller throttle cable guide (11-2338) designed for CV type throttle cables. **See Picture 2.** The two throttle cable guides are interchangeable on the carburetor body, and can be changed very easily to update older carburetors or to accommodate custom throttle cables which are not stock for a particular year chassis.

1981 to Present Sportster Models

Stock Sportster models from 1981 to 1987 have two cable throttle system designed for butterfly type carburetors. Sportsters from 1988 to present have a two cable throttle system designed for use with the stock constant velocity (CV) type carburetor. Since the taller #11-2338 cable guide bracket can not be used on a Sportster chassis due to insufficient frame clearance, throttle cables on Sportsters originally equipped with a CV type carburetor must be changed to butterfly style cables. S&S can supply the correct style throttle cables. **See S&S Throttle Cable Application Chart.**

1996 to Present Buells

1996 and 1997 Buells require special S&S butterfly style throttle cables for Buells, which are compatible with the stock 1996-1997 throttle assembly. 1998 and later carbureted Buells require installation of stock 1996 – 97 throttle grip and the special S&S Buell style throttle cables when installing Super E or G carburetors.

S&S Throttle Kits

S&S throttle kits fit 1" handlebars and can be used on most chassis. (An adapter sleeve is available for use with earlier, 7/8" OEM handlebars originally equipped with internal throttle cable.) Barrel fittings on S&S cables readily "plug in" to S&S Super E, G, and stock H-D 1981-'90 butterfly type carb throttle linkage. Kits include one opening and one closing side cable, left and right grips, and handlebar clamps. Kits with 36", 39", 42", or 48" length cables are available. Length specified refers to overall cable length. Vinyl covered outer housing is 4" shorter than overall length.

Throttle Kit with 36" cables	Part #19-0450
Throttle Kit with 39" cables	Part #19-0448
Throttle Kit with 42" cables	Part #19-0482
Throttle Kit with 48" cables	Part #19-0449
Adapter Sleeve - 7/8" to 1"	Part #19-0235

NOTE – Cables supplied with above kits are interchangeable with 1981-'90 stock H-D butterfly style throttle cables.

S&S Throttle Cables For 1996 and Later Chassis

These throttle cables feature the "plug in" cable fastener to fit 1996 and later throttle grips, and the correct length inner cable for use with S&S butterfly style carburetors with the shorter #11-2339 cable bracket. These cables must be used in 1996 and later Sportster installations. These cables may be used on 1996 and later Big Twin installations if the S&S carb is equipped with the short (#11-2339) cable guide bracket. Buell* style cables fit threaded 1996-97 Buell throttle grip.

S&S THROTTLE CABLE APPLICATION CHART				
Length Total Housing	Length Vinyl Housing	Part Number Open Side	Part Number Close Side	Fitment
36"	32"	#19-0430	#19-0431	For Buell with 7/8" handlebars
36"	32"	#19-0432	#19-0433	To '95 '81-'85 FX and FL; All '81-'85 XL (Also pre-'81 w/2-cable throttle housing replaced.) For Buell with 1" diameter handlebar
36"	32"	#19-0436	#19-0437	'96-Up 883-1200 XL
39"	35"	#19-0434	#19-0435	To '95 Softail (FXSTC, FXST, FLSTC, FLSTF) '86-'94 FXR, '93-'95 Dyna
39"	35"	#19-0438	#19-0439	'96-Up Softail (FXSTS, FXSTC, FLSTC, FLSTF) '96-Up Dyna
42"	38"	#19-0446	#19-0447	To '95 custom application
42"	38"	#19-0440	#19-0441	'96-Up custom application
48"	44"	#19-0462	#19-0463	To '95 All FLT Models
48"	44"	#19-0464	#19-0465	'96-Up All FLT Models

Super E and Super G Carb Kits - Complete					
		Super E Carb Kits with Manifolds		Super G Carb Kits with Manifolds	
Application	Year & Type of Engine	Carb Kit Standard	Carb Kit w/5 Gallon Tank\$	Carb Kit Standard	Carb Kit w/5 Gallon Tank\$
Big Twin	1955-'65 BT*	11-0401	11-0401		
	1966-'78 BT	11-0402	11-0415	11-0422	11-0435
	1979-'82 BT	11-0403	11-0416	11-0423	11-0436
	1983-'84 BT	11-0411	11-0417	11-0431	11-0437
	1984-'89 BT	11-0407		11-0427	
	1990-'92 BT	11-0410		11-0430	
	1993-up BT	11-0419		11-0434	
Sportster	1957-'78 XL ‡	11-0404		11-0424	
	1979-'82 XL	11-0405		11-0425	
	1983-'85 XL	11-0406		11-0426	
	1986-'90 XL	11-0408		11-0428	
	1991-up XL	11-0409		11-0429	
Buell	1994-up Buell	11-0448		11-0449	
Twin Cam	1999-up Twin Cam 88	11-0450		11-0451	

Carb Installation and Operation

Refer to "Super E and G Carb Kit Application Charts" to confirm that carb kit is correct one for your motorcycle. Read instructions thoroughly to familiarize yourself with all procedures before beginning installation.

NOTE - Installation of S&S Super E and G carb kits on certain models is easier with gas tanks removed. Some owners may elect to perform installation without removing gas tanks. This is left to individual discretion. If installer elects to remove tanks or other stock parts, S&S recommends referring to appropriate H-D service manual for correct removal procedure as necessary.

1. Remove Old Carburetor

WARNINGS

- Gasoline is extremely flammable and explosive under certain conditions. Do not smoke around gasoline. Gasoline fumes are toxic when inhaled. Perform installation in a well ventilated area away from open flames or sparks. Any gasoline leak or spill constitutes a health and fire hazard.
- If motorcycle has been running, wait until engine and exhaust have cooled to avoid getting burned during installation.
- Electrical sparks can ignite explosive gasoline fumes. Failure to disconnect battery while working on motorcycle can also result in inadvertent engagement of starter and personal injury.

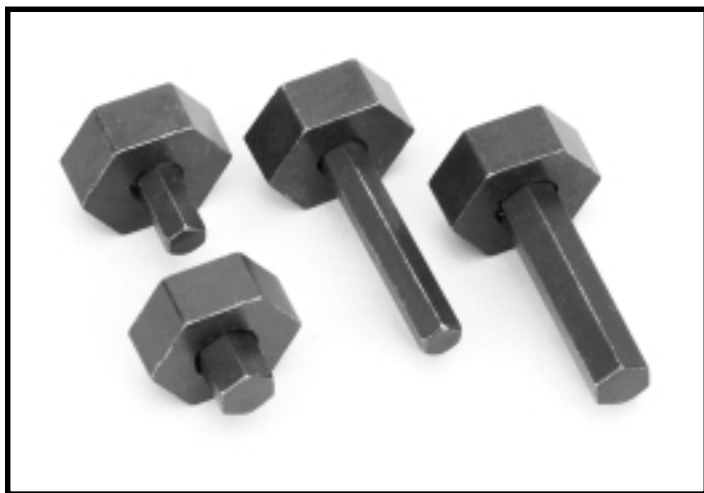

Picture 3

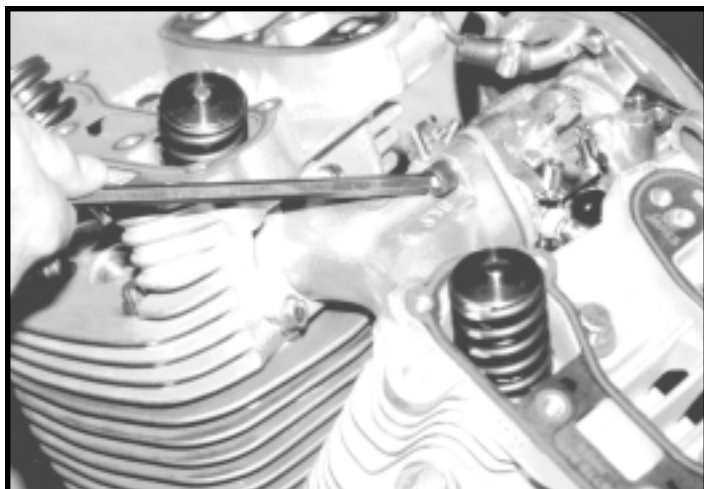

Picture 4

Super E and Super G Carb Kits - Partial					
		Super E Carb Kits without Manifold		Super G Carb Kits without Manifolds	
Application	Year & Type of Engine	Carb Kit Standard	Carb Kit w/5 Gallon Tank§	Carb Kit Standard	Carb Kit w/5 Gallon Tank§
Big Twin	1955-'65 BT*	11-0412			
	1966-'78 BT	11-0412	11-0418	11-0432	11-0438
	1979-'82 BT	11-0412	11-0418	11-0432	11-0438
	1983-'84 BT	11-0412	11-0418	11-0432	11-0438
	1984-'89 BT	11-0440		11-0444	
	1990-'92 BT	11-0440		11-0444	
	1993-up BT	11-0442		11-0446	
Sportster	1957-'78 XL ‡	11-0414		11-0439	
	1979-'82 XL	11-0414		11-0439	
	1983-'85 XL	11-0414		11-0439	
	1986-'90 XL	11-0440		11-0444	
	1991-up XL	11-0443		11-0447	
Buell	1994-up Buell				
Twin Cam	1999-up Twin Cam 88	11-0453		11-0454	
Carb Only	All year groups	11-0420		11-0421	

- A. Shut off fuel petcock and disconnect battery.
- B. Remove air cleaner assembly. Drain fuel from existing carburetor. Remove carburetor, manifold, choke cable and any carburetor mounting hardware

NOTES

- Removing and tightening hard to reach Allen bolts such as carb-manifold mounting bolts and V² or Twin Cam manifold flange bolts can be greatly simplified by the use of some special tools. The S&S rocker cover wrenches work very well for this application. **See Picture 3.** Allen ball-end drivers are also very helpful, and are available at most automotive and tool supply houses. **See Picture 4.** Additionally, Performance Plus of Evansville, Indiana, produces a hex wrench specially modified for accessibility of V² and Twin Cam manifold bolts. Call 812-963-8854 for further information. As an alternative, standard hex wrench can be shortened for convenience.
- Some Buell motorcycles have a breather fitting with 90° elbow on rear head. Due to proximity of frame, elbow must be removed before fitting can be taken off engine. Loosen fitting and rotate to position convenient for cutting elbow. Secure fitting by tightening against cylinder head. Elbow may be inaccessible to hacksaw. In most instances, a die grinder with cutoff wheel will remove elbow with little difficulty. If die grinder is unavailable, grasp elbow firmly with pliers and snap off, then remove fitting.

CAUTION - Extreme care must be taken to prevent metal chips from entering engine when elbow is removed. S&S recommends packing breather fitting with grease before removing elbow. Metal chips inside engine will cause extensive damage. Installer bears all responsibility for containment of chips and other debris.

2. Prepare Air Cleaner Backplate

NOTE - Fast idle lever screws, part #11-2384, must not be over tightened. Loctite or other thread locking compound may be used sparingly on threads to prevent screws from vibrating loose.

CAUTION - Over tightening fast idle lever screws may damage backplate.

- A. All Pre V²s
 1. Knuckles & Pans, 1936 to 1965 - Press plugs, part #50-8312, into holes in air cleaner backplate. **See Picture 5.**

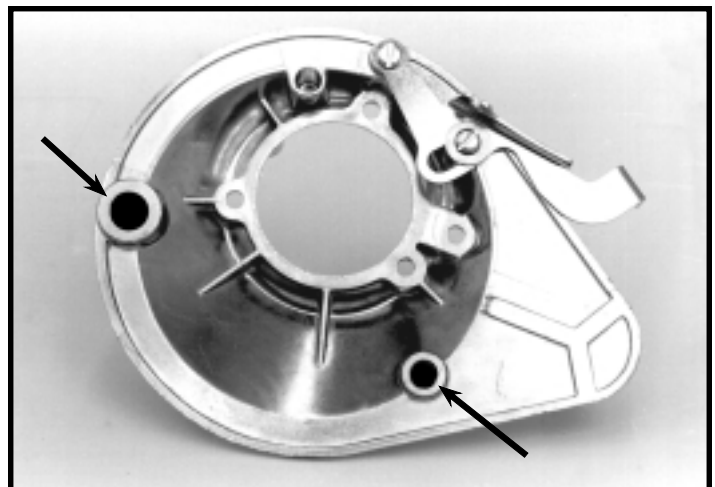

Picture 5

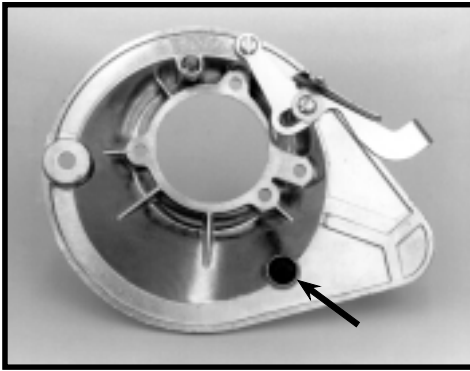

Picture 6

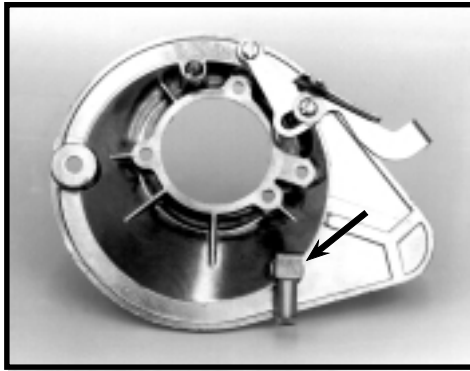

Picture 7

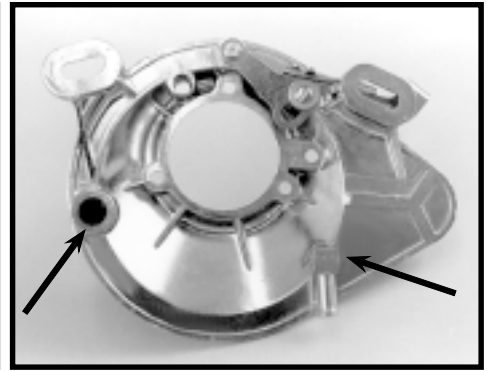

Picture 8

2. Shovels, 1966 to 1979, and Ironhead (IH) XLs, 1957 to 1979 - Press plug, part #50-8312, into hole in air cleaner backplate. **See Picture 6.**
 3. Shovels 1980 to 1984 and IH XLs 1980 to 1985 - Screw crankcase breather vent elbow fitting, part #50-8110, into hole in air cleaner backplate and angle downward as shown in **Picture 7.**
 4. On 1983 and 1984 Shovels press plug, part #50-8312, into other hole on left.
 5. Assemble fast idle mechanism as shown in **Figure A.**
- B. FL V²s 1984 to 1992
1. Press plug, part #50-8312, into hole on left in air cleaner backplate as shown in **Picture 8.**
 2. Screw vent hose elbow fitting, part #50-8110, into remaining hole at right. **See Picture 8.**
 3. Assemble fast idle mechanism as shown in **Figure A.**
- C. XL V²s 1986 to 1990
1. Press plug, part #50-8312, into hole on right in air cleaner backplate as shown in **Picture 9.**
 2. Screw vent hose nipple fitting, part #50-8111, into remaining hole at left. **See Picture 9.** Elbow fitting, part #50-8110, supplied in kit may also be used in this location if required.
 3. Assemble fast idle mechanism as shown in **Figure A.**
- D. FL V²s 1993 and up, XL V²s 1991 and up, and Twin Cams 1999 and up.
1. Press plugs, part #50-8312, into both holes in air cleaner backplate as shown in **Picture 10.**
 2. Assemble fast idle mechanism as shown in **Figure A.**
- E. Buell motorcycles, 1994 and up - Assemble fast idle mechanism as shown in **Figure A.**

3. Throttle Preparation

NOTE - Throttle grip assembly must be assembled correctly and work freely to prevent possible sticking during operation. Throttle must snap closed when released. Cable routing must be free of tight bends to minimize friction between cable and housing.

WARNING: If throttle does not work freely, it may inadvertently stick open possibly causing loss of control of motorcycle and personal injury to operator or others.

- A. Install new throttle assembly - Motorcycles not equipped with two cable pull open-pull closed type throttle assembly.
1. Remove existing throttle cables and throttle grip assembly. Note routing of stock cables.
 2. Install new throttle assembly and throttle cables. Position grip and cables similar to stock position so cables can be angled back toward carb for easy adjustment and free operation.

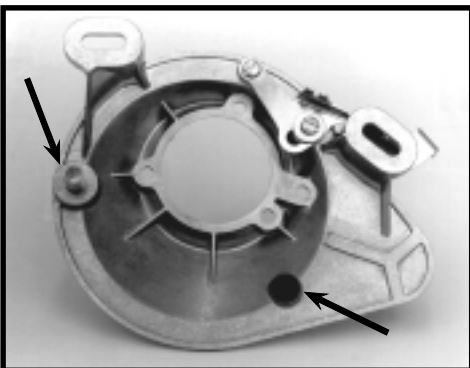

Picture 9

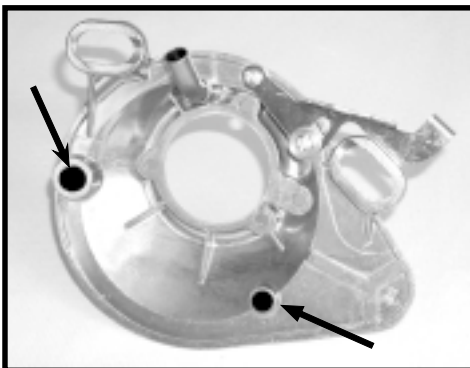

Picture 10

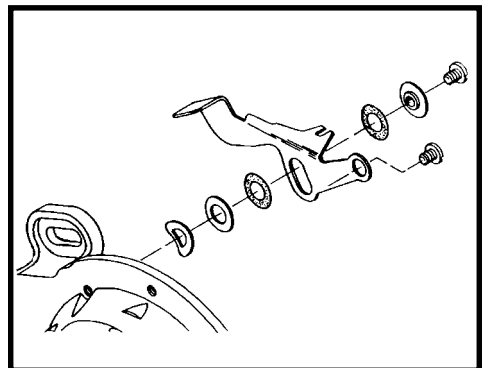

Figure A

3. Apply light coat of cable lubricant to cables and fittings.
 4. Loosen cable freeplay adjustment locknuts and thread adjusting screw so half of threads are exposed. **See Picture 11.**
- B. Prepare existing throttle assembly - 1981-1989 XL and 1981 and later Big Twin chassis equipped with two cable pull open-pull closed type throttle assembly.
1. Loosen cable freeplay adjustment locknuts and thread adjusting screw so half of threads are exposed. **See Picture 11.**
 2. Clean grease and dirt off cables, cable housings and cable fittings.
 3. Apply light coat of cable lubricant to cables and fittings.
- C. Replace throttle cables - all 1988 and later Sportster and Buell models equipped with constant velocity (CV) type carb.
1. Carefully remove existing cables noting how they are routed.
 2. 1998 and later Buells – replace throttle assembly with stock 1996-'97 throttle assembly.
 3. Install replacement cables using same routing as stock cables.
 4. Loosen cable freeplay adjustment locknuts and thread adjusting screw so half of threads are exposed. **See Picture 11.**
 5. Apply light coat of cable lubricant to cables and fittings.



Picture 11

NOTE - Cylinder heads for Knuckles 1936-1947 and Pans 1948-1954 must be converted to o-ring style manifold and seals. Conversion kits are available from various aftermarket sources.

- B. All models: Install S&S intake manifold. If applicable, vacuum advance fitting must point upward. For V² and Twin Cam style manifold flange and seal assembly order, **See Figure B**. Note that bevel side of seal goes toward recess in manifold flange, flat side of seal against head. Do not completely tighten manifold clamps or flange bolts at this time.
- C. Panheads - Remove center crankcase stud nut between tappet blocks. Install bracket, part #16-0096, to connect bottom carb-manifold mounting bolt to crankcase stud and reinstall nut.
- D. Shovelheads 1966 to 1982 - Bolt bracket, part #17-0392, to front rocker cover using $\frac{5}{16}$ -18 x $\frac{5}{8}$ " bolt, $\frac{5}{16}$ " flatwasher and $\frac{5}{16}$ " lockwasher provided in kit. Do not tighten at this time. End of bracket with sharp bend goes toward rocker cover.
- E. Shovelheads 1983 to 1984 - Remove center crankcase stud nut between tappet blocks. Install bracket #16-0471 to connect lower carb-manifold mounting bolt to crankcase stud and reinstall nut.
- F. IH XL's 1957-1982 - Bolt bracket, part #17-0393, to front tappet guide using $\frac{5}{16}$ -18 x $1\frac{1}{4}$ " bolt, $\frac{5}{16}$ " flatwasher and $\frac{5}{16}$ " lockwasher provided in kit. Do not tighten. End of bracket with sharp bend goes toward tappet guide.

4. Install New Manifold and Mounting Hardware

NOTE - When applicable, all carburetor mounting brackets and hardware supplied in kit must be installed to secure carburetor and air cleaner backplate assembly or air horn rigidly to engine.

CAUTIONS

- **Improperly mounted carburetor could loosen unexpectedly, resulting in air leak, poor performance and possible damage to engine or carburetor.**
- **Incorrect combinations of mounting hardware may cause mounting bolts to bottom out in holes or inadvertently contact other parts possibly causing damage to engine or carburetor components.**

WARNING - Improperly mounted carburetor may break free in event of collision or other vehicle accident creating a fire hazard with potential personal injury to operator and others.

- A. All models: Clean intake ports on cylinder heads to insure proper manifold to head seal.

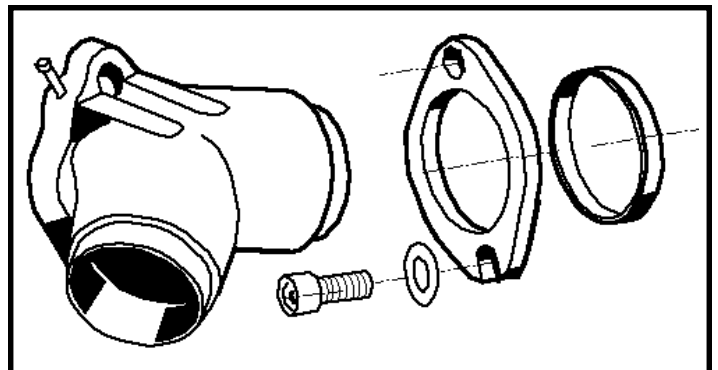
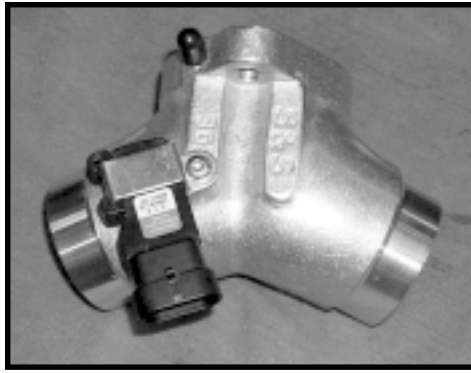

Figure B



Picture 12



Picture 13



Picture 14

NOTE - E and G carb will not fit IH XL models equipped with OEM style magneto due to interference between magneto and carb fuel inlet fitting. S&S manufactures no adapters or other components for installing E or G carb on magneto equipped Sportster.

- G. IH XL's 1983 to 1985 and all V²s - Connect vacuum operated advance ignition switch (VOES) to manifold using 8" piece of black tubing supplied in kit. Cut tubing to shorter length if necessary.
- H. Twin Cams 1999-up - Install stock map sensor in S&S manifold. **See Picture 12.** Secure sensor to manifold with stock clip and screw. **See Picture 13.** Install manifold on engine with stock hardware. Connect fuel petcock vacuum hose to manifold fitting and connect wiring harness to map sensor. **See Picture 14.**

5. Install Carb

- A. Check idle mixture and idle speed screw settings.
 1. Check setting of idle mixture screw, part #11-2354, on top of carb body. **See Picture 15.** Turn screw clockwise to close screw, counting number of turns to fully closed position - setting should be 1½ turns. Reset by turning screw counterclockwise to 1½ turns open. After engine is started, screw must be reset as explained in "Adjusting Idle Mixture" section of instructions.

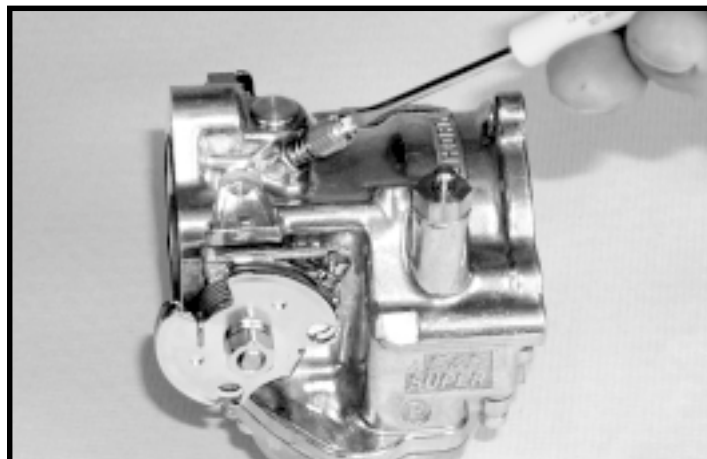

Picture 15

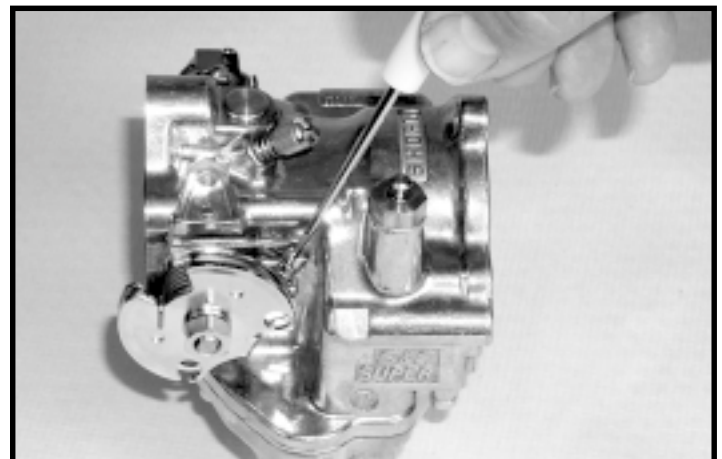

Picture 16

NOTE - Turn idle mixture screw in only far enough to contact seat. Do not over tighten.

CAUTION - Over tightening idle mixture screw may cause irreversible damage to carburetor body.

- 2. Check setting of idle speed adjusting screw, part #50-0038. **See Picture 16.** Turn screw counterclockwise until it no longer contacts throttle linkage spool, part #11-2385. Next, turn screw clockwise until it just contacts spool. Then turn additional ½ turn clockwise to slightly open throttle plate, part #11-2055 (E carbs) or part #11-2355 (G carbs).
- B. Install throttle cables on carburetor.
 1. Locate throttle cable housing bracket, part #11-2338 or #11-2339, in carburetor kit.
 2. Install opening side throttle cable barrel fitting and throttle cable in throttle linkage and appropriate side of throttle cable housing bracket. Opening side cable housing outside diameter is smaller and measures .190".
 3. Repeat step 2 for closing side throttle cable. Closing side cable has a spring around inner cable wire. **See Picture 17.**
 4. Apply drop of Loctite 242 or equivalent to threads of cable bracket screw and reinstall bracket on carburetor.
- C. Install carb on manifold

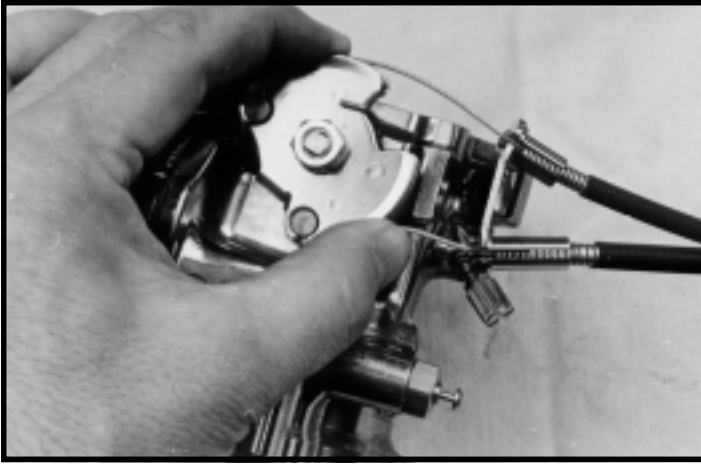

Picture 17

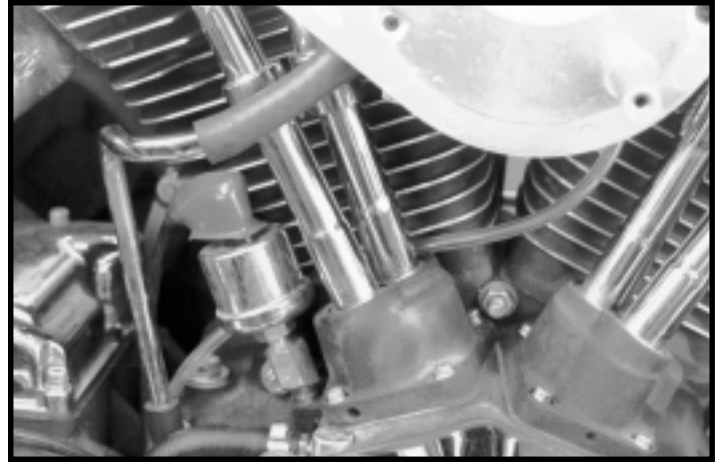

Picture 18

1. Bolt carb and insulator block to intake manifold using two $\frac{3}{8}$ -16 socket cap screws provided in kit. (O-ring side of block faces manifold.) Most carb kits for Big Twins include two $\frac{3}{8}$ -16 x $1\frac{1}{4}$ " socket cap screws. Knuckle/Pan and 1983-'84 Shovel kits include one $1\frac{1}{4}$ " screw and one $1\frac{3}{8}$ " screw. The $1\frac{3}{8}$ " screw is longer to compensate for thickness of support bracket (part #16-0096 for Pan/Knuckles or #16-0471 for 1983-'84 Shovels) and must go in bottom hole. Kits for Evolution Sportsters sold after 6-15-01 contain a thicker ($\frac{3}{8}$ ") insulator block and two $\frac{3}{8}$ -16 x $1\frac{3}{8}$ " socket cap screws to compensate for the additional thickness of the spacer block. (See important note and caution below concerning insulator block.)

NOTE - If insulator block is not installed, manifold bolts supplied in kit will be too long and may bottom in holes. Shorter manifold bolts must be used if insulator block is not installed.

CAUTION - If insulator block is not installed, lower manifold bolt may damage carburetor bowl causing possible gasoline leak.

WARNING - Gasoline is extremely flammable and explosive under certain conditions. Do not smoke around gasoline. Gasoline fumes are toxic when inhaled. Any gasoline leak or spill constitutes a health and fire hazard.

- D. Adjust throttle cables
 1. Turn threaded throttle cable adjusters to remove excessive freeplay.
 2. Test throttle to insure that it opens and closes freely. Turn handlebars to extreme left and open and close throttle, then turn bars to extreme right and open and close throttle. If throttle binds, loosen cable adjusters to put more freeplay in cables. Tighten adjusting screw locknuts after making final adjustments.

NOTE - Throttle must not bind and must snap shut to fully

closed position when released.

WARNING - If throttle does not return to fully closed position when released, it may inadvertently stick open, causing possible loss of control of motorcycle and personal injury to operator or others.

- E. Slip fuel overflow hose onto fitting on carb bowl and neatly route behind pushrod tubes. On Big Twins hose should go toward back of engine. On Sportsters hose should go toward front of engine. Exit end of overflow hose must extend down below engine and away from exhaust pipes. **See Pictures 18 and 19.**

WARNING - Overflow hose must not contact hot surface such as exhaust pipe where it could melt and catch fire.

- F. Slip hose clamp over end of fuel line with 90° bend. Apply thin coat of oil to carb fuel inlet fitting and slip end of fuel line with 90° bend on fitting. Position fuel line in such a way as to avoid contact with cylinders and other hot engine parts. Tighten hose clamp. Slip protective fuel line covering over fuel line and position where contact with engine parts could occur. On models equipped with fuel line support guide, use guide if possible. Connect other end of fuel line to gas tank petcock using hose clamp provided.

NOTE - Some early Super E and G carbs were equipped



Picture 19



Picture 20

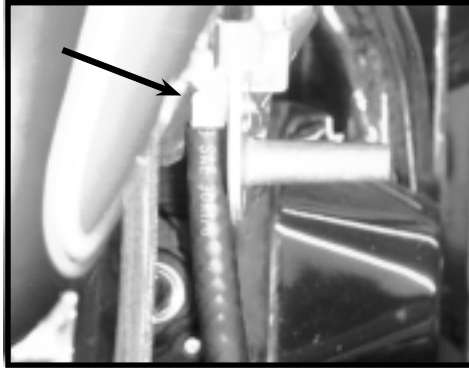

Picture 21

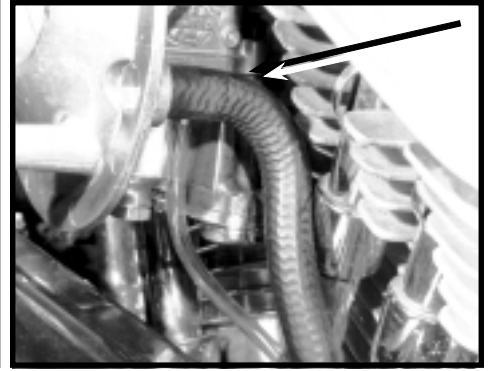

Picture 22

with a swivel type fuel inlet. This inlet is no longer available. If swivel inlet requires repair, it must be replaced with straight inlet #11-2465, o-ring #11-2027, and 90° fuel line #19-0474 or #19-0475. See carburetor parts list and line drawing on page 24.

WARNING - Fuel line must be clamped securely and not contact hot surfaces such as exhaust pipes where it could melt and catch fire.

6. Install Air Cleaner Backplate

NOTE - Air cleaner backplate screws supplied with kit have thread locking compound on threads. If screw without thread locking compound is used, a thread locking product such as Loctite 242 must be applied, and screws properly tightened.

CAUTION - Failure to apply thread locking compound or properly tighten screws may cause screws to loosen and fall into engine, causing engine damage not covered under warranty.

- A. Shovels 1966 to 1982 and all Ironhead XL's
 1. Mount air cleaner backplate on carb using three $\frac{3}{4}$ -20 x $\frac{5}{16}$ " screw/washer assemblies. Confirm that enrichment device lever, engages enrichment device plunger. **See Picture 20.** Tighten backplate mounting screws to 10-12 ft-lbs.
 2. Bolt carb mounting bracket to air cleaner backplate. Head of $\frac{5}{16}$ -18 x 1" bolt should rest in hex recess on inside of backplate with threaded portion extending through backplate, two $\frac{1}{8}$ " shims and bracket. Secure with $\frac{5}{16}$ "

flatwasher and locknut provided.

3. Final tighten all mounting bracket bolts and manifold clamps.
4. Shovels and Sportsters 1980 to 1985 - Connect crankcase breather hose to air cleaner backplate hose fitting. **See Pictures 21 and 22.**

C. FL V's 1984 to 1992 and XL V's 1986 to 1990

1. 1992 FL models with crankcase breather vented from cases to air cleaner backplate - Install thread-sert, part #50-8151, in each cylinder head air cleaner mounting bolt hole. This converts stock $\frac{1}{2}$ -13 thread to $\frac{5}{16}$ -18 thread. Surface of thread-sert should be just below surface of cylinder head. **See Picture 23.**

NOTES

- Most 1992 FL's have crankcase breather routed from case to air cleaner backplate. However, some late 1992 engines have breather routed from heads to air cleaner backplate through air cleaner mounting bosses. If crankcase breather is routed through heads, 1993 and later carb kit must be installed. Follow instructions for installation on 1993 engine.
- Thread-serts may be supplied with or without thread locking compound on threads. Loctite 242 or equivalent should be applied to threads of thread-serts not supplied with thread locking compound. Thread-serts should be installed in desired position and left in place. Installing thread-sert in hole activates thread locking compound making it difficult to change position of thread-sert after installation.



Picture 23



Picture 24



Picture 25

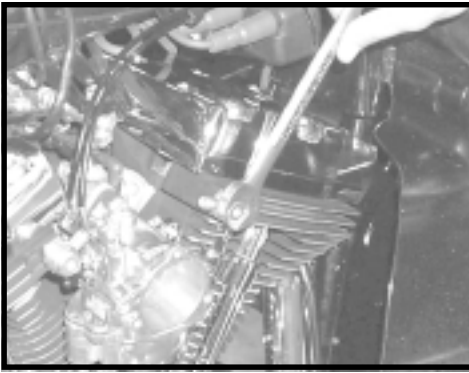

Picture 26

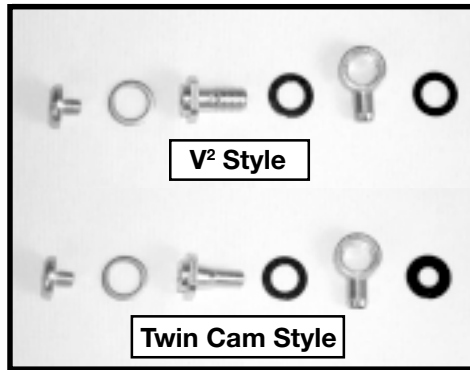

Picture 27

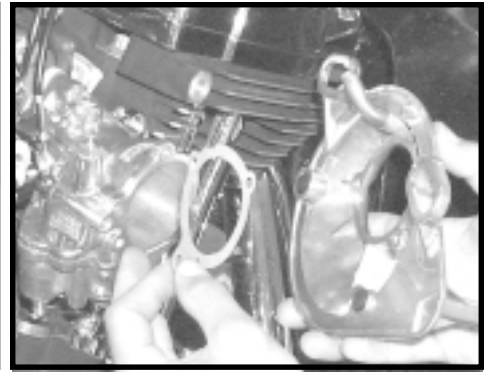

Picture 28

CAUTION - Cylinder head vent passages in “head breather” type engine must not be plugged as oil leakage and engine damage may result. Same applies to crankcase vent in “case breather” type engine.

2. Mount air cleaner backplate on carb using three $\frac{1}{4}$ -20 x $\frac{9}{16}$ " screw/washer assemblies. Confirm that enrichment device lever, engages enrichment device plunger. **See Picture 20.** Tighten backplate mounting screws to 10-12 ft-lbs.
 3. Fill gap between backplate mounting ears and cylinder heads with shims provided in S&S shim kit, part #17-0314.
 4. Bolt backplate to cylinder heads with $\frac{5}{16}$ -18 x $\frac{1}{4}$ " bolts, flat washers and lock washers. **See Picture 24.**
 5. Final tighten all mounting bracket bolts and manifold clamps.
 6. Connect crankcase breather hose to air cleaner backplate hose fitting. **See Pictures 21 and 22.**
- D. FL V²s 1993 and up (kits sold before 2/1/01) and XL V²s 1991 and up (kits sold before 6-15-01)(Now obsolete).
1. Mount air cleaner backplate on carb using three $\frac{1}{4}$ -20 x $\frac{9}{16}$ " screw/washer assemblies. Confirm that enrichment device lever, engages enrichment device plunger. **See Picture 20.** Tighten backplate mounting screws to 10-12 ft-lbs.
 2. Place washer #50-7119 on breather screw #17-0338.
 3. Roll $\frac{5}{8}$ " O.D. o-ring #50-8032 into large diameter o-ring groove closest to head of breather screw.
 4. Roll $\frac{1}{2}$ " O.D. o-ring #50-8006 into small diameter o-ring groove of breather screw. Apply thin film of light grease to o-rings.
 5. Repeat for other breather screw.
 6. Hold “banjo” breather fitting behind backplate ear with larger diameter hole toward backplate. Fill gap between fitting and cylinder head with shims provided in S&S shim kit. **See Picture 25.** Repeat for other head.
 7. Thread breather screw into cylinder head through backplate ear, breather fitting and shims. Repeat for other backplate ear.
8. Align breather fitting outlets and tighten breather screws.
- NOTE - Breather fitting o-rings are easily damaged. It is suggested that replacements be obtained prior to removing breather fittings in future.*
9. Slip hose clamp #50-8002 over short “tee” of vent hose #17-0339 and push hose “tee” onto nipple fitting on rear of backplate with long hose runner toward rear cylinder breather fitting. Position hose in such a way that it is not kinked and does not interfere with travel of the enrichment lever. Trim ends of vent hose as required. Push hose ends onto breather fittings. Secure hose ends on breather fittings with small wire ties #50-8003 supplied in kit. Secure short “T” of breather hose to backplate with hose clamp #50-8002 supplied with kit.
 10. Final tighten all mounting bracket bolts and manifold clamps.
- E. FL V²s 1993 and up (kits sold after 2/1/01), XL V²s 1991 and up (kits sold after 6-15-01), and all Twin Cams 1999 and up.
1. Install breather fittings in heads. **See Picture 26.** Apply red Loctite to threads and torque to 15-20 ft-lb. **See Picture 27** for component placement.
 2. Install breather hose between breather fittings with long hose runner toward rear cylinder breather fitting. Position hose in such a way that it is not kinked and does not interfere with travel of the enrichment lever. Trim ends of vent hose as required. Secure hose to fittings with small wire ties #50-8003.
 3. Install backplate and gasket. Connect the short “T” of the breather hose to the steel nipple fitting on the back of backplate. **See Picture 28.** Secure hose to backplate fitting with hose clamp #50-8002. Confirm that fast idle lever has properly engaged enrichment plunger. Tighten screws holding backplate to carburetor to 10-12 ft-lbs.

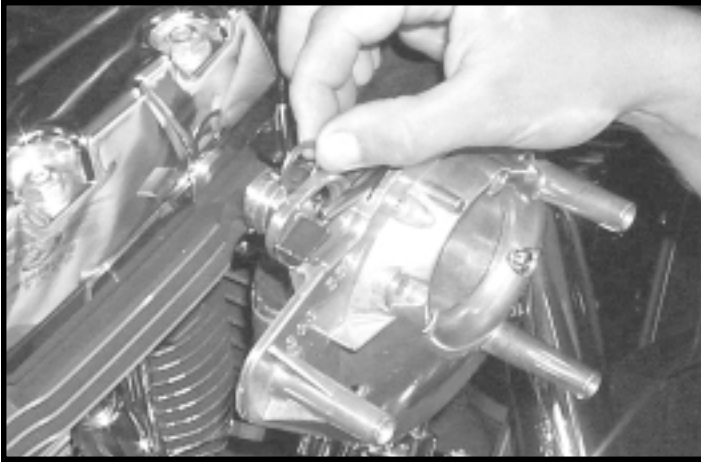

Picture 29

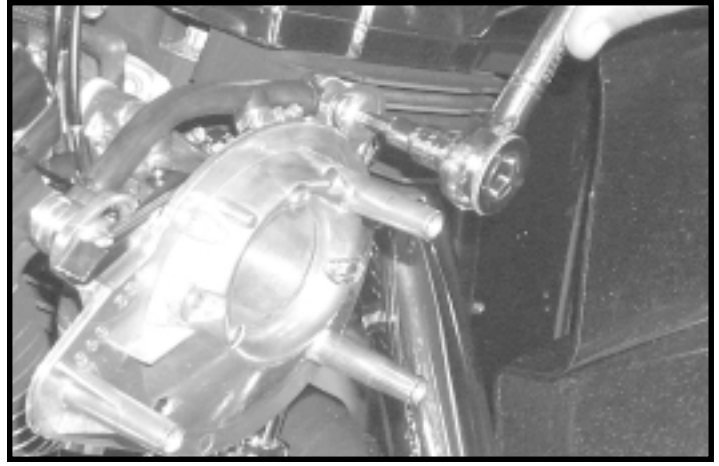

Picture 30

4. Determine which of the provided shims correctly fills the gaps between backplate and breather fittings. **See Picture 29.**
 5. Fill gap between backplate mounting ears and cylinder heads with correct shims. Install #17-0346 screws to attach backplate to breather fitting. Torque to 8-12 ft-lb with no Loctite. **See Picture 30.**
- F. Buells 1994 to present
1. Place washer #50-7119 on breather screw #17-0338.
 2. Roll $\frac{5}{8}$ " O.D. o-ring #50-8032 into large diameter o-ring groove closest to head of breather screw.
 3. Roll $\frac{1}{2}$ " O.D. o-ring #50-8006 into small diameter o-ring groove of breather screw. Apply thin film of light grease to o-rings.
 4. Repeat for other breather screw.
 5. Loosely install #17-0309 bracket on front head using spacers and breather banjo bolt assembly. **See Picture 31.** Install banjo bolt assembly in rear head, but do not tighten.
6. Position of #17-0309 backplate support bracket must be determined before backplate can be permanently installed. Temporarily install backplate. Rotate bracket to align hole in bracket with hole in backplate. Mark position of bracket with pencil mark on cylinder head to act as guide for final installation. Remove backplate.
 7. Place ends of rubber T-hose #17-0339 over breather fittings for trial fit. **See Picture 32.** Temporarily install backplate using correct number of spacers. Hose must be routed so as to be free of kinks and not interfere with operation of fast idle lever.
 8. Remove backplate, shorten hose ends as needed for correct fit, reinstall hose and secure with tie-wraps #50-8003. Tighten banjo bolt breather screws.
 9. Install backplate for final assembly. Confirm that fast idle lever has properly engaged enrichment plunger and secure backplate to support #17-0309 with $\frac{1}{4}$ " bolt, flat washer, and locknut provided. Tighten three backplate screws #50-0075 to 10-12 ft-lbs.

NOTE - At least one thick spacer will be required between breather banjo fittings and heads. Breather fitting o-rings are easily damaged. It is suggested that they be lubricated with light grease before installation. If possible, replacement o-rings should be obtained beforehand if banjo assemblies are removed in future.

NOTE - Backplate screws supplied with kit have pre-applied thread locking compound on threads. If screw without thread locking compound is used, a thread locking compound such as Loctite 242 must be applied to threads, and screws properly tightened. If screws are removed in future, Loctite 242 or equivalent must be applied before reinstallation.

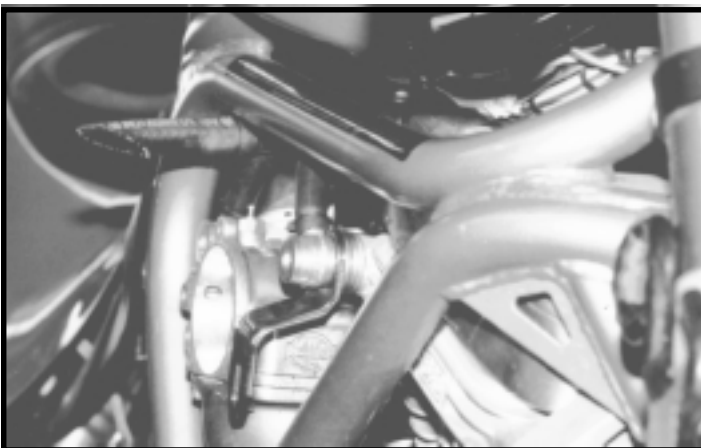

Picture 31

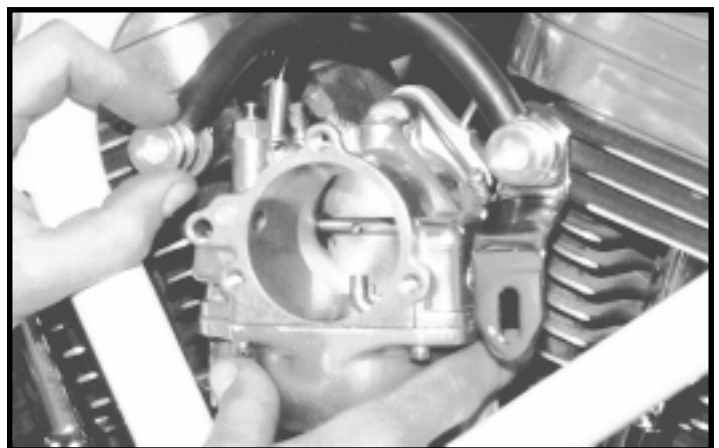

Picture 32

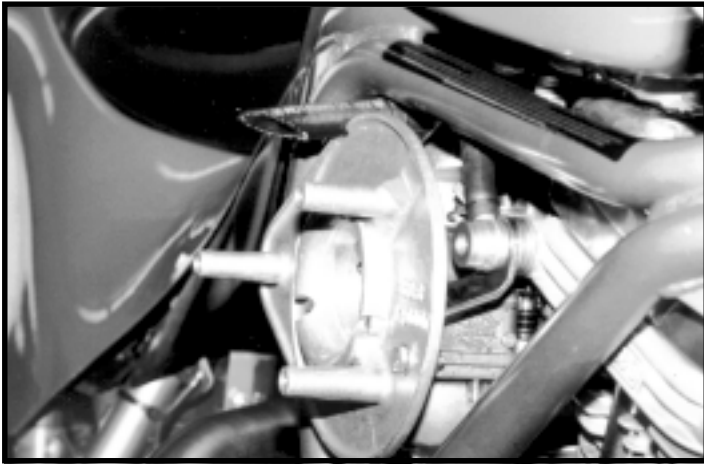

Picture 33



Picture 34

CAUTION - Failure to apply thread locking compound or properly tighten screws may cause screws to loosen and fall into engine, resulting in engine damage not covered under warranty.

10. For street use, insert 1¼" steel tubing provided into short "tee" of T-hose and place ⅜" OD x 2.80" hose over other end of tubing. Hose must rest in notch in backplate, with bevel down. Secure with Tie-wraps when correctly positioned. **See Picture 33.**

NOTE - An additional, 36" length of hose is provided for "Race Only" applications. It should be attached to T-hose in place of 2.80" hose, and routed to overflow or "catch can" as required by event organizer. Breather hose should be routed in upward direction as much as possible. Because crankcase oil-air mist exits from hose, hose and catch can must be mounted securely and well away from hot or moving parts as well as tires and brakes.

WARNING - Oil on tire or brakes can result in loss of control of motorcycle, resulting in possible serious injury or death to operator and others.

7. Final assembly and checks.

- A. Check carb to manifold mounting bolts.
- B. Check carb to air cleaner backplate mounting screws.
- C. Check each of following that is applicable:
 - Carb mounting bracket to head bolts.
 - Mounting bracket to air cleaner backplate.
 - Mounting bracket to center case stud.
 - Mounting bracket to tappet guide bolt.
 - Mounting bracket to head breather vent fitting.
 - Air cleaner backplate to head mounting bolts.
- D. Check fuel line connections and routing. Avoid hot surfaces.
- E. Check vacuum operated ignition advance connections if applicable.
- F. Check crankcase to backplate vent hose connections if applicable.
- G. Check fuel overflow hose routing. Avoid hot surfaces.

- H. Test throttle to be sure it opens and closes freely. Turn handlebars to extreme left and open and close throttle, then turn bars to extreme right and check throttle. When released, throttle should snap closed in all positions.
- I. Reassemble components that were removed or disassembled for carb installation. Consult authorized H-D service manual for installation procedure for stock parts not covered in S&S carb instructions.
- J. Check fuel needle and seat assembly. Fill gas tank with just enough fuel to test system. Lean motorcycle over towards carburetor side, turn on fuel petcock and wait 20 seconds. If gas runs out end of carb or out overflow hose, turn off petcock and check needle and seat. See "General Information."
- K. Check fuel inlet fitting and fuel line connections for leaks. Hose clamps must be tight.

NOTE - Fuel needle and seat assembly must completely shut off fuel supply to carburetor bowl. Fuel inlet fittings and fuel line connections must not leak.

CAUTION - Gasoline leaking past inlet needle may flood engine causing contamination of oil supply and damage to engine.

WARNING - Any gasoline leak represents a health and fire hazard.

- L. Install air cleaner element and air cleaner cover using three ¼"-20 x 1" mounting screws provided. Flat side of pleated filter element #17-0376 goes against air cleaner backplate. Insure that element goes around outside edge of locating tang at 9 o'clock position on backplate. Rounded side of element with S&S Part # goes toward outside. Correctly installed element will remain in place on backplate without support. Filter element supplied with carb kits for Buells is foam type. Beveled vent hose in Buell style kits must rest in notch in backplate and go between air cleaner element and chromed outer cover. Hose bevel should angle down toward element. **See Picture 34**



Picture 35

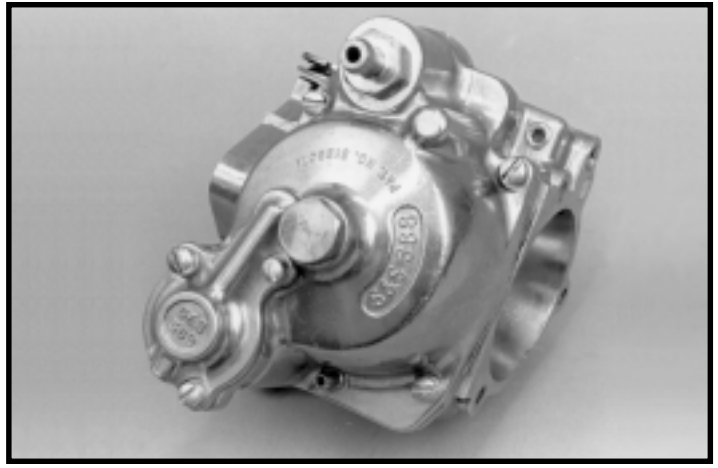

Picture 36

NOTE – Pleated air filter element supplied in carb kits for Big Twins and Sportsters goes on dry. Do not apply filter oil to pleated filter. Foam filter element supplied in Buell carb kits may be installed dry or foam type filter oil may be applied. Foam filter elements may be washed and reused, but pleated elements must be replaced when they become dirty or clogged.

M. Fill gas tank.

INSTALLATION NOTES

- In designing the S&S Super E and G carbs S&S has made every effort to keep overall assembled length as short as possible. Due to the short installed length of the carb assembly, the air cleaner cover may contact the gas tank of four speed Shovelheads. In such instances an optional chromed, notched cover, part #17-0372, that will provide additional clearance can be ordered. **See Picture 35.** If a new, undamaged Super E/G cover is shipped to S&S prepaid, it will be exchanged for part #17-0372 for the difference in cover prices. Call for Return Authorization (RA) number before shipping cover. An optional 1" spacer block can be installed between carb and manifold as an alternative, or existing air cleaner cover modified to provide $\frac{1}{8}$ " minimum clearance.

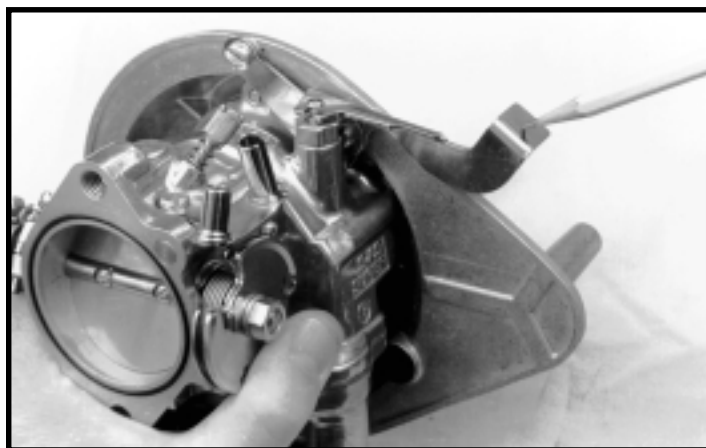

Picture 37

- Bowl vent screw, part #50-0105 (**See Picture 36**), should be removed for any all-out racing application which includes use of air horn or air cleaner without filter element. Exposed passage in carb body maintains equal pressure between float bowl and atmosphere.
- On any application where air horn is used instead of air cleaner, S&S carb mounting bracket, part #16-0471, must be used to securely fasten carb to engine. See line drawing on page 28.

CAUTION - Improperly mounted carburetor may loosen from engine resulting in gas or air leaks, poor performance and possible damage to carburetor or other components.

WARNING - Any gasoline leak represents a potential health and fire hazard.

- G carb using air cleaner assembly without filter element flows approx. 7 CFM (10" test pressure) less than carb with 4" air horn. E carb w/air cleaner assembly, no filter, flows same as with 4" air horn. S&S recommends using air filter element for all street applications.
- S&S has found that trimming approximately $\frac{3}{4}$ " off rim of S&S air cleaner cover has resulted in as much as 3 HP increase on Dynojet 150 chassis dynamometer. However, this increases exposure of filter element to weather and contamination, so filter should be inspected regularly and washed or replaced as needed.

Carb Operation

1. Starting Procedure - S&S Super E & G carburetors do not have a conventional choke. Instead, a mixture enrichment/fast idle device is used for starting and engine warm-ups. The enrichment device utilizes separate air and fuel pickup passageways and is engaged by pulling fast idle lever, part #17-0329 (**See Picture 37**) upward. E & G carburetors also feature a fully adjustable accelerator pump which is actuated by quick throttle movements at partial throttle openings and can be used as an additional starting aid.

ENRICHMENT DEVICE NOTES

- Enrichment/fast idle pickup tube located directly below fast idle plunger, part #11-2343, is pressed into carburetor body and must not be removed. See **Picture 38**.

CAUTION - Removal of enrichment/fast idle pickup tube from carburetor body may cause irreversible damage to carburetor.

- Plunger nut, part #11-2344, plunger spring, part #11-2340, and plunger, part #11-2343, may be removed for cleaning purposes.
- If air cleaner backplate is removed, be sure fast idle lever and enrichment plunger are engaged properly when backplate is reinstalled. See **Picture 20**.
- S&S enrichment system operates on manifold vacuum. If throttle is opened while starting engine, vacuum will be reduced and enrichment system will not function normally.

A. Cold Starts

1. Open fuel petcock.

NOTE - When motorcycle is not running, fuel petcock/shutoff valve should be turned off to prevent possible leakage should needle and seat not seal properly.

CAUTION - Gasoline leaking past inlet needle may flood engine causing oil contamination and engine damage.

WARNING - Gasoline leaking past inlet needle may flood engine and surrounding area creating a potential health and fire hazard.

2. Prime engine with one or more squirts from accelerator pump. Ambient temperatures below 60° may require increased priming, up to 6-7 squirts depending upon exact temperature and carb jet size.
3. Pull fast idle lever, part #17-0327 or part #17-0329, to fully raised position.
4. Turn on ignition.

NOTE - Some engines, especially those equipped with magnetos, will start easier if given two prime kicks BEFORE ignition is turned on. For reliable starting, magneto should be equipped with kill button to disable ignition for prime kicks.

5. With throttle closed, kick engine through or engage electric starter.
6. If engine fails to start immediately, crack throttle enough to barely open butterfly and continue to kick or engage starter until engine fires.
7. After engine starts, position lever to maintain rpm at approximately 1000-1200 rpm with throttle closed. Lever may gradually be pushed down to closed position as engine warms. Engine should be warmed sufficiently to idle with fast idle lever off in 1 to 4 minutes or after a few miles of riding.

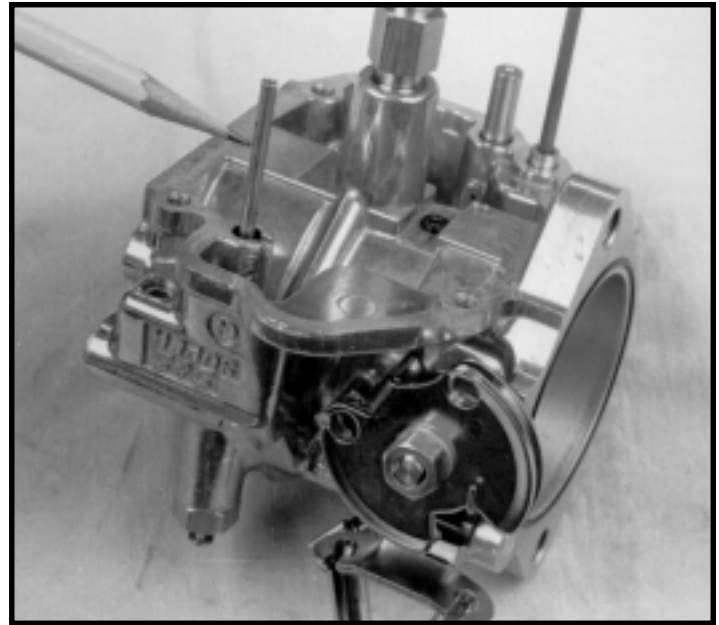

Picture 38

NOTE - Operating engine with fast idle lever up for excessive time will result in fouled spark plugs. Push lever completely down as soon as engine will run smoothly without enrichener.

B. Hot Starts

1. Open fuel petcock.
2. Turn on ignition.
3. With throttle closed, kick engine through or engage electric starter.
4. If engine fails to start immediately, open throttle slightly and continue to kick or engage starter until engine fires.

C. Troubleshooting Tips - engine will not start:

1. Fuel supply exhausted.
2. Weak or no spark - discharged battery, worn points, faulty condenser, ignition module, coil, spark plug wires, or magneto.
3. Plug gap too wide - S&S uses .025" to .030" plug gap on engines with points type ignition and stock coil. Electronic ignitions and high output coils can run wider plug gaps.
4. Improper ignition timing - Worn or poorly maintained mechanical advance units sometime stick in advanced position causing hard starting, kick-back and erratic idle.
5. Tight tappet adjustment. If solid tappets are adjusted too tightly, valves may not seat properly, and the loss of compression may prevent the engine from starting.
6. Improper idle mixture and/or engine idle rpm setting. If idle mixture is set incorrectly, throttle plate must be opened farther with the idle speed screw in order to maintain idle speed. This reduces manifold vacuum and makes the enrichment circuit less effective. See "Adjusting Carburetor - Idle Circuit."

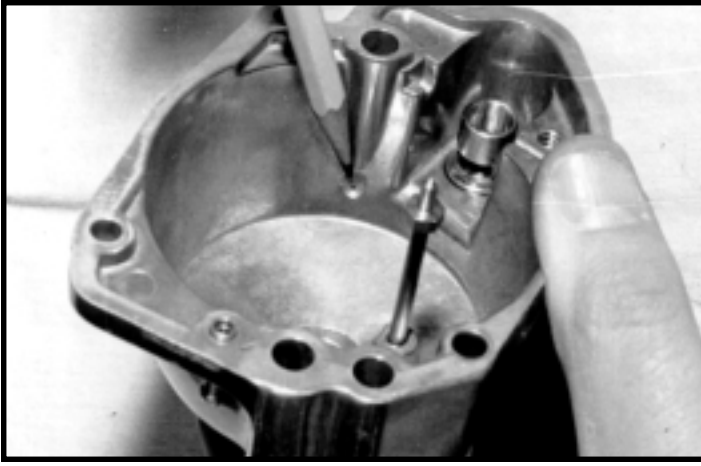

Picture 39

7. Enrichment device feed hole (See Picture 39) in bowl plugged. Clear with compressed air.

CAUTION - Do not use wire or drill to clear hole. If size of hole is changed, starting system will be altered and carburetor bowl irreversibly damaged.

WARNING - Compressed air and particles dislodged by compressed air are potentially harmful to eyes and body. Wear protective goggles when using compressed air and always direct air stream away from yourself and others nearby.

8. Improper diagnosis of rich or lean mixture condition. If engine backfires in carb, mixture is usually lean and engine must be reprimed. If there is no response after three kicks or if engine pops in exhaust pipes, mixture is probably too rich. Leave switch on and slowly open throttle $\frac{1}{4}$ turn with each successive kick until engine fires.
9. If engine was running properly before installation of carburetor, no other changes were made and carb settings were confirmed as instructed previously, hard starting is likely caused by incorrect intermediate jet or starting routine. Remain calm and patient while attempting to start motorcycle, and experiment with different starting procedures (throttle and enricher position, number of squirts from accelerator pump, etc.), especially with kickstart motorcycle. Carb tuning and ignition tuning and maintenance are critical for kick start motorcycles.

If severe flooding is suspected, turn ignition off, slowly roll throttle to wide open position, and kick 6-8 times to clear engine. Then close throttle to approximately $\frac{1}{8}$ turn, turn ignition on and kick until engine starts.

If insufficient fuel is suspected, remove air cleaner cover and confirm accelerator pump operation by snapping throttle open from closed position. Fuel

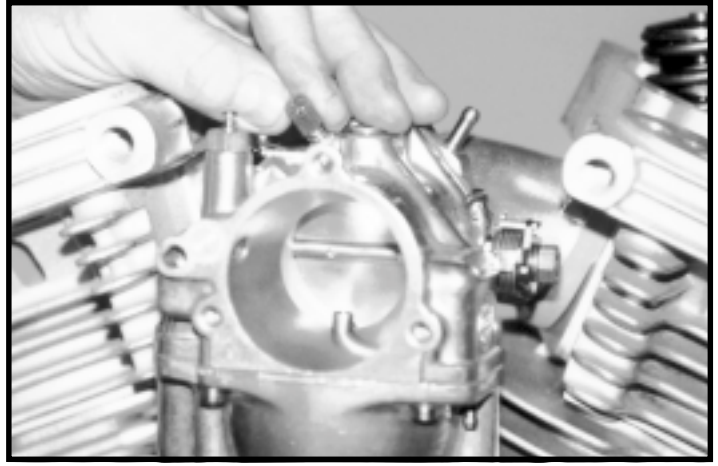

Picture 40

should exit accelerator pump nozzle directly behind main discharge tube in carburetor bore. If not, increase accelerator pump setting by turning adjustment screw out, in counterclockwise direction. Replace air cleaner cover and attempt to start motorcycle according to procedure previously described.

If more than 2-3 squirts from accelerator pump are required to start motorcycle with temperature 60° or above, larger intermediate jet may be required. This may also be caused by incorrect idle mixture adjustment or a manifold leak. Refer to following sections for additional information on tuning.

2. Adjusting Carburetor

- A. Adjusting Idle Circuit - Idle mixture screw, part #11-2354 (See Picture 40), regulates air/fuel mixture at idle speeds and has been angled forward for greater accessibility. Throttle stop/engine rpm adjustment screw, part #50-0038 (See Picture 41), is located on boss on rear side of carburetor body. During assembly S&S adjusts both screws to settings that should work for first start-up after installation.

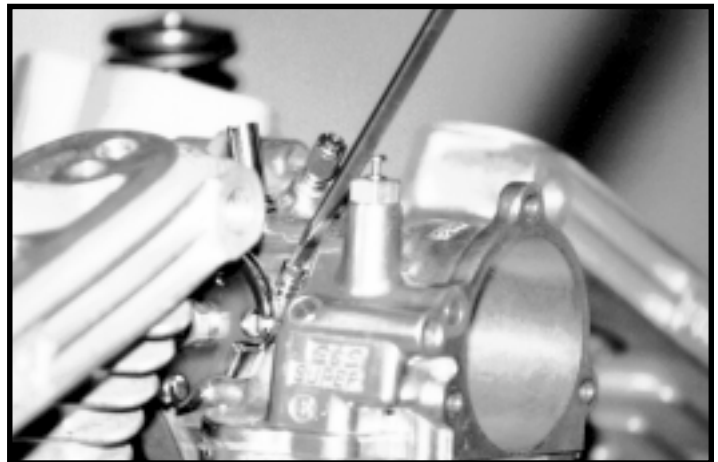

Picture 41

1. Start engine and run until slightly warm (approximately 1 to 2 minutes).
2. Turn RPM adjustment screw, #50-0032, to obtain idle of approximately 1000 RPM.
3. Turn idle mixture screw, #11-2354, clockwise, slowly leaning mixture until engine starts to die. Next, turn screw counterclockwise, slowly richening mixture, until engine RPM fall off. Mixture adjustment is correct when screw is positioned about halfway between these points, or approximately $\frac{1}{4}$ to $\frac{1}{2}$ turn out from lean side of adjustment range.

NOTE - Turning screw out (counterclockwise) makes idle mixture richer. Turning screw in (clockwise) makes mixture leaner. Normally, correctly adjusted screw will be between $1\frac{1}{4}$ and $1\frac{3}{4}$ turns out from bottom if intermediate jet size is correct. Note that mixture screw must be adjusted according to Step 3 above. Do not leave screw at initial $1\frac{1}{2}$ turn setting without fine tuning.

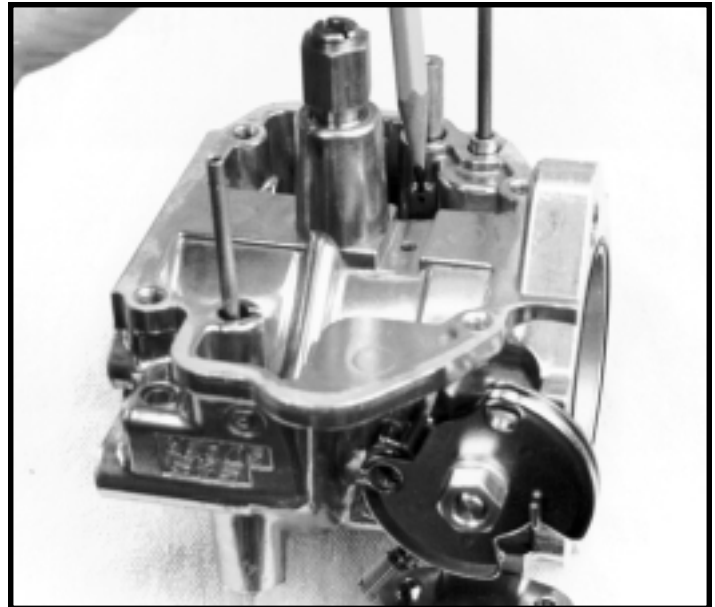

Picture 42

4. After initial idle mixture adjustment, reset engine idle to approximately 1000 RPM. Lower idle speed can cause hard starting, poor throttle response, erratic idle and unnecessary engine wear.
5. After engine has reached normal operating temperature, repeat Steps 3 and 4.

IDLE CIRCUIT NOTES

- If idle adjustments are made before engine is fully warmed, idle mixture will be rich when engine reaches operating temperature. This is especially true for engines with aluminum cylinders such as V²'s. If ambient temperature is below 60 degrees, engine may require 10-15 minutes of normal riding to reach operating temperature.
- Whenever intermediate jet change is made, idle mixture screw must be readjusted.
- If the idle mixture screw is more than $1\frac{3}{4}$ turns out after idle mixture is correctly adjusted, it is a fairly good indication that the intermediate jet may be too small and should be changed to the next larger size. If the idle mixture screw ends up less than $1\frac{1}{4}$ turn out, the intermediate jet may need to be changed to the next smaller size. Be aware that idle mixture screw adjustment can be effected by other factors, but can quite often indicate rich or lean intermediate jetting.
- If idle mixture screw is turned completely in, engine should not run at idle. If engine continues to run at idle with idle mixture screw seated, recheck initial setting of idle speed screw, and make sure enrichment plunger is seated. If the engine still runs at idle with the idle mixture screw turned all the way in, contact S&S Technical Services Department.

- B. Troubleshooting Tips - engine will not idle:
 1. Improper idle mixture or rpm setting.
 2. Intake manifold air leak.
 3. Malfunctioning automatic advance mechanism or other ignition problem.
 4. Foreign material in air or gas passageway in carb causing gas flow restriction to idle or intermediate circuit. **Picture 42** shows intermediate air bleed metering hole. **Picture 43** shows intermediate jet metering hole. Clear holes with compressed air.

CAUTION - Do not use wire or drill to clear hole. If size of hole is altered, starting system will be altered and carburetor bowl irreversibly damaged.

WARNING - Compressed air and particles dislodged by compressed air are potentially harmful to eyes and body. Wear protective goggles when using compressed air and always direct air stream away from yourself and others nearby.

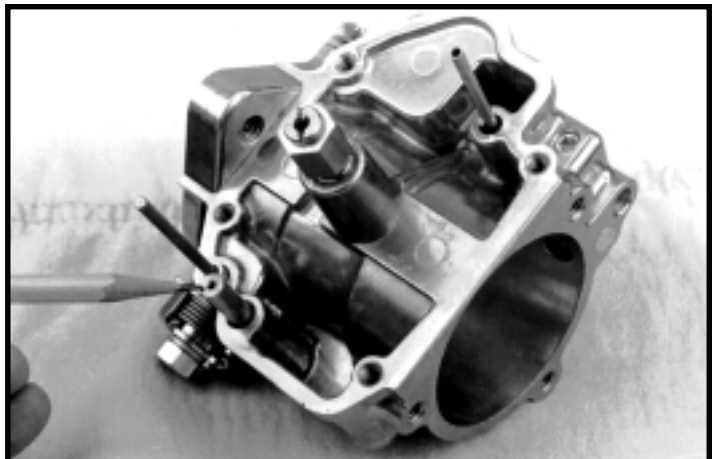

Picture 43

5. Enrichment/fast idle plunger, part #11-2343, not seated causing excessively rich mixture. Be sure enrichment lever, part #17-0329, is fully disengaged (in down position) allowing plunger to bottom and seal passageway. Remove air cleaner backplate. Lift and release plunger several times, letting it “snap” closed to fully seat against carb body. When backplate is reinstalled on carb, be sure lever is engaged in plunger properly and that plunger is not lifted as mounting screws are tightened. **See Picture 20.**
6. ¼” insulator block between carb and manifold omitted. Heat transfer from manifold to carb may cause temporary rich condition at idle and low rpm when engine restarted after being shut off for 10 to 20 minutes. Install insulator block to minimize heat transfer.

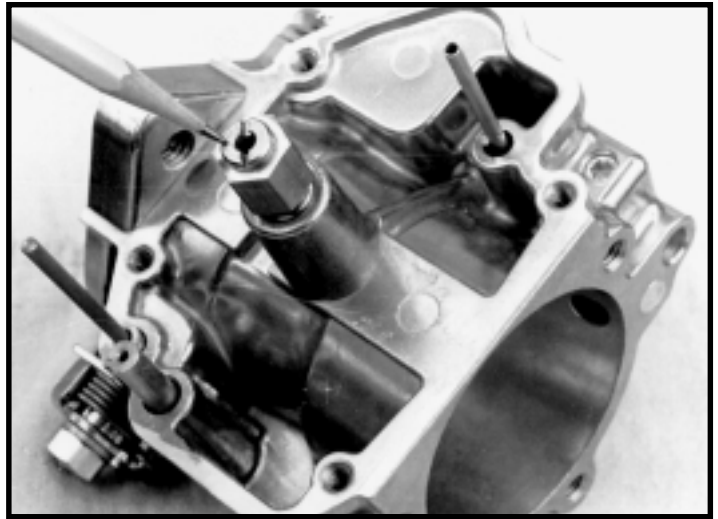

Picture 44

- C. Adjusting Intermediate System - (See Jetting Chart Page 23) Intermediate range is used most often under normal riding conditions. It controls fuel delivery from just off idle to approximately 2500-3000 rpm or 55 to 60 mph depending on gearing. Close attention must be paid when selecting intermediate jet to achieve optimum performance and best gas mileage. Intermediate jet (**See Picture 43**), is reached by removing float bowl assembly. Size of metering hole in intermediate jet is stamped in thousandths of an inch on end or side of jet. Size of intermediate jet installed in new carburetor from S&S is indicated on tag attached to carb or on printed label on carburetor packing box. Keep this information handy for future reference, especially when contacting S&S Technical Services Dept. for assistance. It is a good idea to record any jetting changes for future reference.

Intermediate Jetting Procedure:

1. Ride motorcycle several miles to bring engine up to normal operating temperature.
2. Check idle mixture adjustment to be sure setting is correct with fully hot engine.
3. Check throttling characteristics by slowly rolling throttle on from a steady speed. This should be done at rpm levels of approximately 2000, 2500, and 3000 rpm. (Depending upon gearing, vehicle speeds will usually be between 30 and 60 MPH). “Popping” or “spitting” (backfiring) in air cleaner indicates lean condition requiring that intermediate jet be changed to next larger size (size is stamped on end or side of jet). *See NOTES at right.*
4. Change jet accordingly, adjust mixture screw and repeat road test. Smallest intermediate jet that eliminates this condition should provide best gas mileage.

INTERMEDIATE SYSTEM NOTES

- *It is helpful to shut off accelerator pump while fine tuning intermediate circuit as fuel supplied by pump can mask jetting symptoms. Consult “Accelerator Pump” section of instructions.*
- *Whenever intermediate jet is changed, idle mixture screw must be readjusted.*
- *Elevation changes:
A simple readjustment of idle mixture screw will often compensate for changes in elevation of several thousand feet. S&S test riders have ridden through changes upwards of 7000 feet without changing jets. In other cases, and depending upon accuracy of initial jetting, a change in intermediate and/or main jet may be required.*
- *Higher elevation makes engine run richer, meaning that smaller jets may be required to correct overly rich condition. Lower elevation, nearer sea level, makes engine leaner so larger jets may be required. While rich condition can cause fouled spark plugs and poor performance, lean condition can result in engine damage. If smaller jets are installed for higher elevation, remember to install larger jets for operation at lower elevation.*
- *Intermediate jet provides majority of fuel under average operating conditions. While it is tempting to change main jet because it is more accessible, in most cases intermediate jet should be changed to properly address elevation/altitude-related problem.*

- D. Adjusting High Speed Circuit or Main Jet - High speed circuit begins around 2500-3000 rpm or 55-60 mph under steady speed conditions, and operates to maximum attainable speed. High speed circuit will be pulled in at much lower rpm if throttle is cracked open. Main jet size is best determined by testing at drag strip or dynamometer because maximum miles per hour, rpm and horsepower are most reliable indicators of correct jetting. Main jet (**See Picture 44**), is reached by removing bowl plug, part #11-2090. (See Jetting Chart Page 23)

High Speed (Main) Jetting Procedure

1. Drag strip/dynamometer procedure
 - a. Sufficiently warm engine to begin testing.
 - b. Make run noting engine rpm and final speed or horsepower.
 - c. Richen main jet by increasing jet size .004" and make second run. Again, note rpm and final speed or horsepower.
 - d. Continue procedure until mph/horsepower falls off.
 - e. Decrease or lean main jet size by .002" to gain best rpm and mph. When making runs on drag strip, strive for consistent miles per hour, not lowest ET.
2. Street Procedure - S&S uses "rpm" method to determine main jet size. Under racing conditions this level is where horsepower peaks and begins to taper off and is where gear shifts occur. Main jet that makes engine accelerate strongest or rpm through gears quickest is correct.

NOTE - Placing engine under load by accelerating uphill may make result of jet change more pronounced and easier to interpret.

- a. Warm engine to operating temperature.
- b. Accelerate rapidly through gears noting how quickly and smoothly engine reaches rpm level where pull of engine begins to fade and gear shift occurs.
- c. If engine backfires in carburetor and sputters or "breaks up" and/or dies during acceleration, increase or richen main jet size .004" larger and road test again. Note engine smoothness and how easily engine reaches rpm where gear shift occurs.
- d. If engine runs flat and sluggish or "blubbers" or will not take throttle, decrease or lean main jet size .004" smaller and road test again. Note engine smoothness and how easily engine reaches rpm where gear shift occurs.
- e. Continue changing main jets until jet which makes engine accelerate or rpm through gears quickest and smoothest is identified. S&S's experience is that jetting about .006" smaller (leaner) than correct will make engine break up and quit. Jetting about .006" larger (richer) will make engine blubber and miss.

NOTES

- *Correct carb jetting is essential for optimum performance on street, strip and dynamometer. Other common causes of poor performance in modified engine are inappropriate exhaust and incorrect ignition timing.*
- *S&S special main jet tool, part #53-0452, is extremely handy for changing main jets. Try it, you'll like it!*

- E. Troubleshooting Tips for Intermediate and High Speeds - Engine will not run at steady speed or rpm or quits for no apparent reason:
 1. Restriction in fuel supply system - Gas tank vent plugged, needle and seat not working properly (See "General Information"), gas petcock too small, or defective vacuum petcock. Stock H-D petcock is generally adequate, but may require running on reserve to provide sufficient fuel for big inch engines. If fuel delivery to carb is questionable, S&S recommends Pingel brand high flow petcock.
 2. Faulty ignition/electrical system - Fouled plugs, worn points or condenser, defective coil or solid state module, improper ignition timing, loose wire, faulty circuit breaker or ignition switch. Many ignition/electrical problems occur repeatedly at same rpm because of vibration specific to that rpm .
 3. Incorrect intermediate and/or high speed jetting. See "Adjusting Carb - Intermediate System" and "High Speed Circuit or Main Jet".
 4. Foreign material in air or gas passageway in carb causing flow restriction. **Picture 42** shows intermediate air bleed metering hole. **Picture 45** shows main discharge air bleed metering hole. Use compressed air to clear holes.

CAUTION - Do not use wire or drill to clear hole. If size of hole is altered, starting system will be altered and carburetor bowl irreversibly damaged.

WARNING - Compressed air and particles dislodged by compressed air are potentially harmful to eyes and body. Wear protective goggles when using compressed air and always direct air stream away from yourself and others nearby.

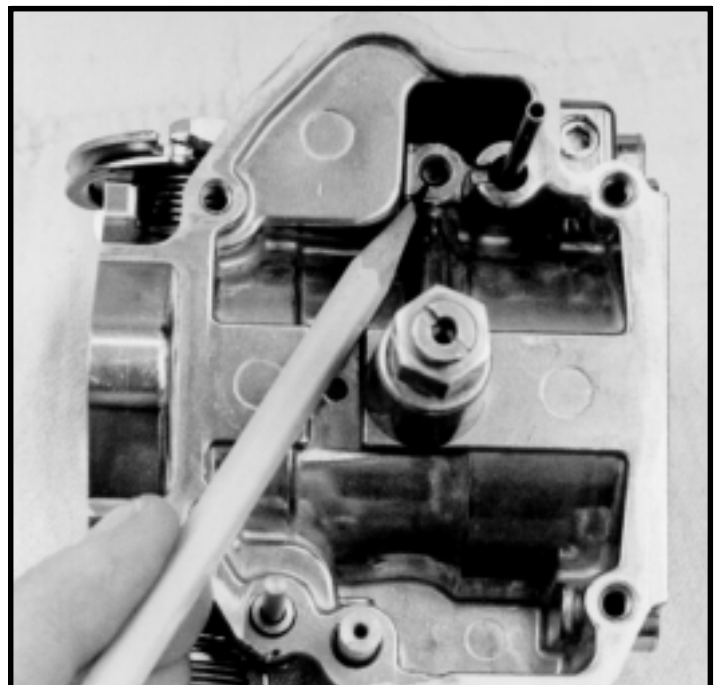

Picture 45

5. Filter oil applied to S&S pleated air cleaner element.

NOTE – Small amounts of engine oil deposited on air cleaner element by crankcase or cylinder head vent is normal and should not cause problem. However, pleated element should not be saturated with air filter oil.

6. No air cleaner used or air cleaner used is brand other than S&S. Some air cleaners restrict air flow so that carb cannot draw air as freely as needed. Also, some air cleaners may obstruct bowl vent hole on inlet end of carb (**See Picture 46**) and change bowl air pressure.

NOTE - Bowl vent hole passage leads to cavity above fuel in bowl. Passage equalizes bowl pressure and atmospheric pressure. If high or low bowl pressure relative to atmospheric pressure develops, engine may run erratically.

7. Insulator block between carb and manifold not used. Heat transfer from manifold to carb may cause temporary rich condition at idle and low rpm when engine is restarted after being shut off for 10 to 20 minutes. Install insulator block to reduce heat transfer.
8. Air cleaner without element or air horn used without removing bowl vent screw, part #50-0105, located in downward facing boss on throttle cable side of carburetor body. **See Picture 36.**
9. Valve train defect - Leaking or sticky valves, weak or broken springs, pushrod flex, improper clearances for high lift cam, or defective camshaft with improper valve timing.
10. Inappropriate exhaust system.

NOTE - S&S has found that long, large diameter exhaust pipes, either baffled or unbaffled, may present insurmountable tuning problems when combined with S&S carburetor. If engine equipped with such pipes does not respond to normal tuning procedure, contact exhaust manufacturer for his tuning suggestions or call S&S for exhaust recommendation.

11. Too much gear - Horsepower insufficient to pull gearing.
12. Incorrect float setting - Setting float too high will cause engine to run rich at idle and at low speeds, and may prevent jet change from correcting over rich mixture. Float setting too low will cause poor off idle response and may cause mixture to "lean out" at high speed or when motorcycle leaned over in curve due to insufficient fuel reserve in bowl. See General Information on Page 23 for float setting instructions and specifications.
13. Fuel standoff - Occasionally, fuel may be seen misting out carburetor when air cleaner is removed. Because carburetor is simply a conduit through which air and fuel enter engine, it does not cause fuel standoff. Usual cause is cam timing.

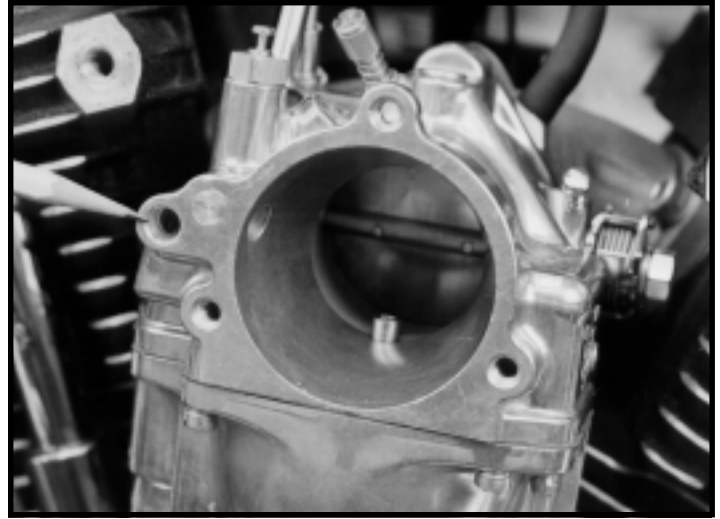

Picture 46

14. Overflow hose missing from the carb bowl can cause engine to miss and break up at high speeds. This problem will more than likely not occur on the dyno because the motorcycle is not moving through the air.

INTERMEDIATE AND HIGH SPEED NOTES

- Carburetor jetting and spark plug color - While spark plug color may be used to help determine carburetor jetting, S&S recommends that our instructions be used as primary jetting guide and that plug color indications be used as secondary aid. Different brands of gasoline, gasoline additives, engine heat, type of plugs, and spark plug heat range can effect plug color making plug reading difficult for average tuner. Also, new plugs usually require road test of 10 miles or more to properly develop color. This means that quarter mile tests may not be long enough to be a good indication of carb jetting. It is best to use recommended spark plug type and to consult spark plug manufacturer with questions.
- If bike is used exclusively on drag strip where engine temperatures vary, slightly richer jets may be necessary to obtain best performance. Larger jets and richer mixtures will enable one to run colder engine which is sometimes desirable. This is best determined by experimentation.
- Cams and exhaust systems can make some engines difficult to carbureate. S&S has found that certain cams and exhaust systems cause poor performance at a specific rpm, and attempts to correct problem with carb tuning usually degrade carburation at other rpm ranges. A combination of cam overlap, reversion, and back pressure, or even lack of back pressure, can cause mixture dilution at certain rpm. This will result in loss of power, engine roughness, or misfiring.

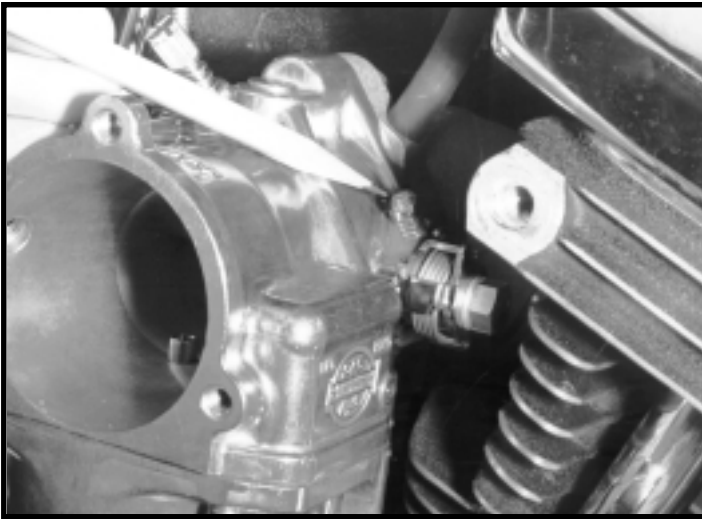

Picture 47

- *Drag pipes - For Knucklehead, Panhead, Shovelhead, and Ironhead Sportster engines, 1³/₄" O.D. drag pipes with straight cutoff end 28" to 30" long will work well with almost any camshaft or other performance modification. 2" O.D. drag pipes are not recommended for any application except very large competition engines. The use of drag pipes is not recommended for Evolution motors in street application.*
- *Muffled exhaust systems - A good, economical street exhaust system consists of stock header pipes with cross-over tube and low restriction mufflers such as Screamin' Eagle/Cycle Shack with CycleShack XP baffles. This system typically produces 10 horsepower more than drag pipes in midrange, where vast majority of normal riding occurs. Some 2-into-1 collector type exhausts such as SuperTrapp and Rich Products Thunderheader deliver even more midrange power. Carl's Speed Shop staggered duals and KhromeWerks AR 100's work extremely well for riders who prefer a more traditional style exhaust. Contact S&S for current exhaust recommendations.*
- *For any all-out racing application which includes use of air cleaner without element or use of air horn, bowl vent screw, part #11-2161 (See Picture 36), should be removed to insure atmospheric air pressure exists in bowl. If high or low bowl pressure relative to atmospheric pressure develops, engine may run erratically.*
- *Modifying S&S carburetor - While it is not S&S's intent to discourage purchase of other manufacturers' products, they should be approached with the understanding that some alter the S&S carburetor's design and function. In such cases, manufacturer of installed item must be contacted for tuning guidelines, not S&S.*

- F. Adjusting Accelerator Pump - Function of accelerator pump is to improve throttle response when rapidly opening throttle at low rpm and to aid cold starts. Pump travel screw, part #50-0039, (See Picture 47), regulates volume of fuel delivered by accelerator pump. During assembly, S&S sets screw for maximum volume to aid during initial start-up after installation. Turning screw inward or in clockwise decreases delivered pump volume. Turning screw outward or counterclockwise increases delivered volume.
1. Warm engine to operating temperature.
 2. Turn pump travel adjusting screw inward or clockwise until screw contacts pump actuator arm, part #11-2377. This limits actuator arm travel and shuts off pump.

CAUTION - Closing adjusting screw with excessive force may cause irreversible damage to screw threads in carburetor body.

3. Perform intermediate and high speed jetting tests to determine proper jetting.
4. With engine warm and at idle, blip throttle and note throttle response.
5. Turn pump travel screw outward or counterclockwise about ¼ turn at a time and recheck throttle response until engine no longer hesitates. This is usually about two turns out.
6. Road test motorcycle noting throttle response at idle and at levels in 500 rpm increments from idle to 3000-3500 rpm.
7. Set pump travel screw at point where best throttle response is noted with minimum pump travel. Minimum pump travel is recommended to conserve fuel, prevent spark plug fouling, and curtail black smoke from pipes when "blipping" throttle. Black smoke from pipes is usually an indication of a rich condition or excessive accelerator pump travel.

NOTE - Final accelerator pump adjustment should be confirmed by riding motorcycle and noting throttle response with motorcycle underway. Because of displacement, compression ratio, cam timing, exhaust design and other, related factors, many engines will stumble or bog if throttle is abruptly cranked fully open with engine at idle. If correct carburetor (E or G) is installed and engine properly tuned and equipped with appropriate exhaust and cam, stumble should disappear under normal riding conditions.

GENERAL INFORMATION NOTES

- Carburetor body has six drilled passages that are permanently sealed with drive plugs.

CAUTION - Removal of these plugs may cause irreversible damage to carburetor.

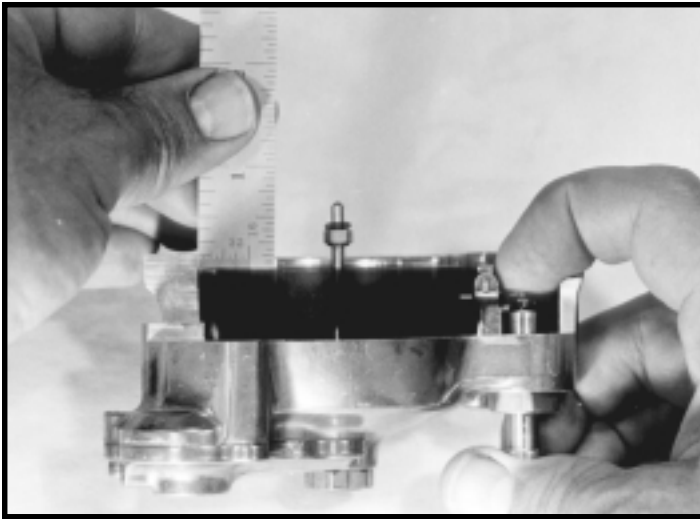

Picture 48

- To insure proper seal so needle completely shuts off fuel supply entering bowl, float hinge, needle lift and needle must work freely and not bind. Float must not contact bowl gasket. If problem is suspected, remove bowl and check float movement. If obvious misalignment, binding or sticking occurs, remove, straighten and reinstall to obtain free movement. Reset float level and double check for free movement. To check, remove bowl (not accelerator pump cap) and raise float until needle is in closed position and spring in top of needle is compressed. Top of float opposite the needle and seat assembly should be $\frac{1}{8}$ " to $\frac{3}{16}$ " below bowl gasket surface. Float must not contact bowl gasket. (See cut away bowl in **Picture 48**.)
- When motorcycle is not running, fuel shutoff valve should always be turned off to prevent possible leakage should needle and seat not seal completely.

CAUTION - Gasoline leaking past inlet needle may flood engine causing contamination of oil supply and damage to engine.

WARNING - Any gasoline leak constitutes a fire and health hazard.

- Throttle plate, part #11-2055 or #11-2355, and throttle shaft, part #11-2383 or #11-2483, should be checked annually for signs of wear. Replace if necessary. If carb body throttle shaft bushings are worn, carb must be returned to S&S for repair. If throttle plate removed, be sure to reinstall correctly. **See Figure C.** Beveled edges of plate must fit flat against carb throat.
- If accelerator pump cap is removed, lift cap slowly so small spring, part #11-2374, checkballs, part #50-8090, and o-rings, part #50-8012 are not lost.

- For racing, S&S offers two air horn conversion kits which include appropriate mounting hardware and a substitute enrichment device. Part #17-0485 includes a 2½" air horn, part #17-0486 includes a 4" air horn.
- If fuel delivery from stock petcock appears insufficient, S&S recommends a Pingel petcock, S&S part #19-0453, which fits most Big Twins, or S&S part #19-0454 (requires S&S part #19-0455), which fits most Sportsters. Tests conducted at S&S have shown Pingel petcocks to provide more than adequate fuel supply for most engines. If in line fuel filter is required, use S&S part #19-0457.

For additional information on these products, contact:

Pingel Enterprise, Inc.

2076 C 11th Avenue

Adams, Wisconsin 53910 U.S.A.

Phone: 608-339-7999 Fax: 608-339-9164

IMPORTANT NOTES

- We at S&S feel we have designed and manufactured a superior product and will stand behind it. If you have questions or problems, first refer to this instruction manual. Answers to nearly all questions can be found herein. If your problem cannot be resolved, call 608-627-1497 for technical assistance. Do not, however, call until you have become thoroughly familiar with this manual.
- S&S also has a complete carburetor repair and rebuild service that provides quality work at a fair price. If you are not properly equipped to service an S&S carburetor and do not have a qualified repair shop nearby, we recommend that you contact us for a Return Authorization (RA) number and send the carburetor to us. Be sure to include a note with your name and address, RA number, and a detailed description of any problems or repairs needed. Thanks for using S&S products!

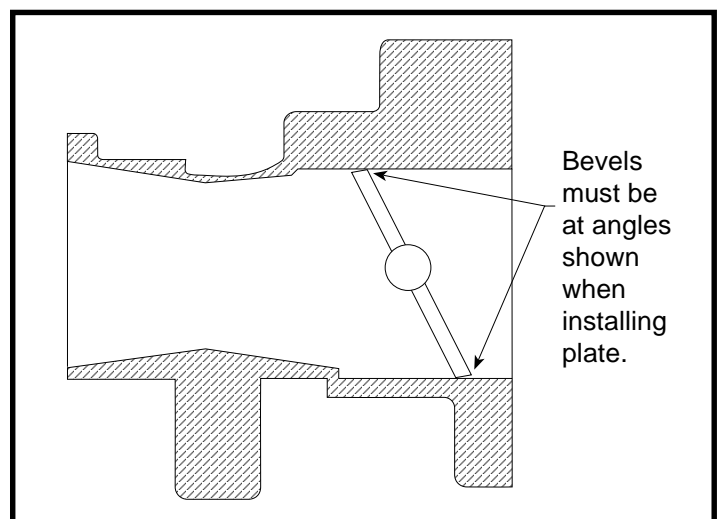

Figure C

Replacement Manifold Parts

1. Intake manifold – Pan
See Section 7 of S&S Catalog for part numbers.
2. Intake manifold – Shovelhead & Ironhead XL
See Section 7 of S&S Catalog for part numbers.
3. Intake manifold – V² and Twin Cam
See Section 7 of S&S Catalog for part numbers.
4. Manifold bolts

$\frac{3}{8}$ " -16 x 1"	#50-0161
$\frac{3}{8}$ " -16 x 1 $\frac{1}{4}$ "	#50-0162
<i>(Use in bottom hole with #16-0096 or #16-0471 bracket or in top and bottom holes with #16-0491 or #16-0492 insulator block.)</i>	
$\frac{3}{8}$ " -16 x 1 $\frac{3}{8}$ "	#50-0163
<i>(Use in bottom hole with #16-0096 or #16-0471 bracket and #16-0491 or #16-0492 insulator block.)</i>	
$\frac{3}{8}$ " -16 x 2"	#50-0164
$\frac{3}{8}$ " -16 x 2 $\frac{1}{4}$ "	#50-0165
$\frac{3}{8}$ " -16 x 2 $\frac{1}{2}$ "	#50-0166
5. Manifold O-ring - 1955 to '78 FL & XL #50-8046
6. Manifold rubberband - 1979 to '85 FL & XL #16-0238
7. Manifold O-ring - V² and Twin Cam

Stock cylinder heads	#16-0236
S&S cylinder heads	#16-0235
8. Manifold clamps

O-ring pre 1979	#16-0230
Band 1979 to '85	#16-0231
9. Manifold Flanges V² and Twin Cam

Front mounting flange	#16-0232
Rear mounting flange	#16-0233
10. Carb mounting bracket - Pan #16-0096
11. Carb mounting bracket assembly #16-0471
(Includes 1 each 2-piece bracket #17-0104, #17-0245, #17-0321.)
12. Support bracket bolt

$\frac{5}{16}$ " -18 x 1"	#50-0108
---------------------------	----------
13. Flat washer – $\frac{5}{16}$ " x $\frac{1}{16}$ " #50-7034
14. Lock nut – $\frac{5}{16}$ " -18 #50-5021
15. 1" Aluminum spacer blocks

For 1 $\frac{1}{8}$ " Super E	#16-0057
<i>(Includes 1 each 1" spacer block & #50-8013 o-ring.)</i>	
For 2 $\frac{1}{16}$ " Super G	#16-0357
<i>(Includes 1 each 1" spacer block & #50-8015 o-ring.)</i>	

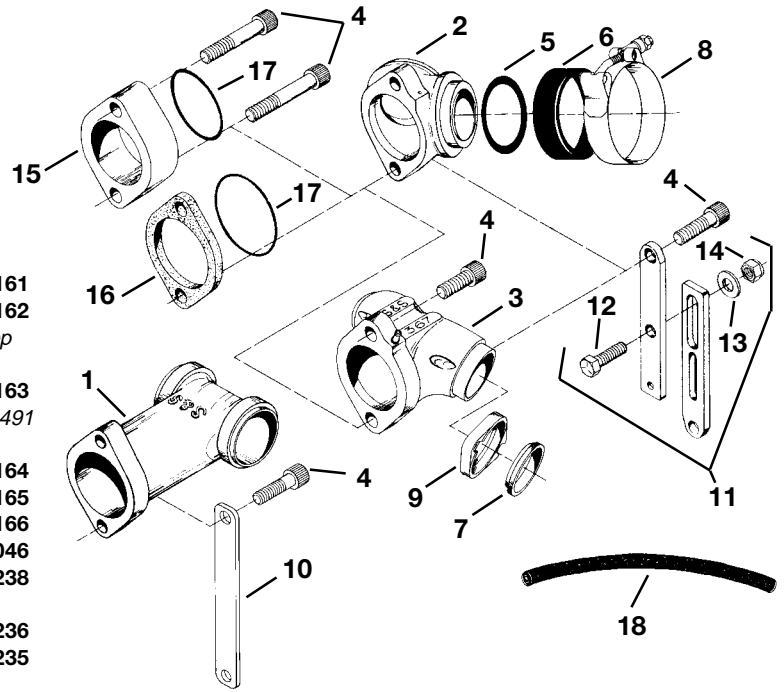

16. Insulator blocks

1 $\frac{1}{8}$ " Super E – All Big Twins	#16-0491
<i>(Includes 1 each insulator block & #50-8016 o-ring.)</i>	
2 $\frac{1}{16}$ " Super G – All Big Twins	#16-0492
<i>(Includes 1 each insulator block & #50-8015 o-ring.)</i>	
1 $\frac{1}{8}$ " E – XL (Manufactured after 6-15-01.)	#16-0497
<i>(Includes 1 each insulator block & #50-8016 o-ring.)</i>	
2 $\frac{1}{16}$ " – XL (Manufactured after 6-15-01.)	#16-0498
<i>(Includes 1 each insulator block & #50-8015 o-ring.)</i>	
17. Manifold orings

For 1 $\frac{1}{8}$ " E carb body & insulator block	#50-8016
For 1 $\frac{1}{8}$ " spacer block	#50-8013
For 2 $\frac{1}{16}$ " G carb body, insulator block, & spacer block	#50-8015
18. VOES tubing - per foot #19-0395

S&S SUPER E JETTING			
Displacement	Stockers 55" to 74"	Stock-Mild Strokers 74" to 84"	Strokers 86" to 98"
Idle Mixture Screw Part #11-2354	1 to 1-1/2 Turns	1 to 1-1/2 Turns	1 to 1-1/2 Turns
Intermediate Jet	883's .0265 to .028 All Others .028 to .0295 Part #11-7101	Ironhead XL's .0295 to .032 All Others .028 to .031 Part #11-7102 or #11-7103	Ironhead XL's .032 to .033 All Others .030 to .033 Part #11-7104
Main Jet	883, 900, 1000 .062 to .068 All Others .066 to .072	74", 80" FL's .066 to .074 All Others .068 to .076	.072 to .082 Part #11-7202

S&S SUPER G JETTING			
Displacement	Stock-Mild Strokers 74" to 84"	Strokers 86" to 93"	Strokers 96" & Up
Idle Mixture Screw Part #11-2354	1 to 1-1/2 Turns	1 to 1-1/2 Turns	1 to 1-1/2 Turns
Intermediate Jet	Stockers .028 to .0295 All Others .0295 to .031 Part #11-7102	Ironhead XL's .031 to .033 All Others .0295 to .033 Part #11-7103 or #11-7104	.032 to .036 Part #11-7105
Main Jet	Stockers .066 to .074 All Others .068 to .076 Part #11-7201	.072 to .080 Part #11-7202	Ironhead XL's .078 to .088 All Others .074 to .086 Part #11-7202

Super E and G Carburetor Body and Related Parts

1. Carb body assembly			
1 $\frac{7}{8}$ " Super E	#11-2381	33. Carb bowl assembly	#11-2388
2 $\frac{7}{16}$ " Super G	#11-2390	34. Bowl plug	#11-2090
2. Throttleshaft		35. Seat/bowl plug o-ring	#50-8009
1 $\frac{7}{8}$ " Super E – (includes 2 ea. #11-2045)	#11-2383	36. Needle - 1 $\frac{7}{8}$ " Super E & 2 $\frac{7}{16}$ " Super G	
2 $\frac{7}{16}$ " Super G – (includes 2 ea. #11-2045)	#11-2483	Street needle (<i>Use with #11-1465 seat.</i>)	#11-2195
3. Throttle plate screw	#50-0029	Racing needle (<i>Use with #11-2466 seat.</i>)	#11-2197
4. Throttle plate		37. Seat - 1 $\frac{7}{8}$ " Super E & Super 2 $\frac{7}{16}$ " G	
1 $\frac{7}{8}$ " Super E	#11-2055	Street seat (<i>Use with #11-2195 needle.</i>)	#11-2465
2 $\frac{7}{16}$ " Super G	#11-2355	Racing seat (<i>Use with #11-2197 needle.</i>)	#11-2466
5. Throttle return spring	#11-2382	38. Ejector nozzle oring	#50-8011
6. Throttle spool	#11-2385	39. Pump pushrod	#11-2373
7. Throttle shaft lock washer	#50-7031	40. Ball check	#50-8090
8. Throttle shaft nut	#11-2350	41. Ball check spring	#11-2374
9. Throttle shaft nylon washer	#50-7050	42. Pump cap oring	#50-8012
10. Pump actuator lever	#11-2376	43. Pump cap assembly	#11-2389
11. Actuator spring	#11-2375	44. Overflow hose per 18"	#19-0262
12. Pump actuator arm	#11-2377	45. Pump cap screw	#50-0042
13. Idle mixture screw	#11-2354	46. Diaphragm spring	#11-2275
14. Idle mixture screw spring	#11-2052	47. Diaphragm	#11-2282
15. Idle speed screw	#50-0038	48. Backplate gasket	#17-0381
16. Pump adjustment screw	#50-0039	49. Enrichment device for air horn	#11-2084
17. Idle speed/pump adjuster spring	#11-2048	50. Fuel line with 90° bend	
18. Plunger nut	#11-2344	19"	#19-0475
19. Plunger spring	#11-2340	51. Fuel line insulator (<i>Not shown.</i>)	#19-0172
20. Enrichment plunger	#11-2343	52. Hose clamp (<i>Not shown.</i>)	#50-8002
Enrichment device (<i>See #49 for use with air horn.</i>)	#11-2084		
21. Cable guide assembly			
Butterfly style cables	#11-2339		
CV style cables	#11-2338		
22. Cable clamp/float pin screw	#50-0041		
23. Mainfold o-ring			
1 $\frac{7}{8}$ " Super E	#50-8016		
2 $\frac{7}{16}$ " Super G	#50-8015		
24. Bellows seal	#11-2266		
25. Bowl vent plug	#50-0105		
26. Main discharge tube	#11-2085		
27. Main jet (See jet section of S&S Catalog.)			
28. Intermediate jet (See jet section of S&S Catalog.)			
29. Bowl gasket	#11-2386		
30. Float	#11-2187		
31. Float pin	#11-2369		
32. Bowl screw			
10-24 x $\frac{3}{8}$ "	#50-0034		
10-24 x 2 $\frac{7}{16}$ "	#50-0040		



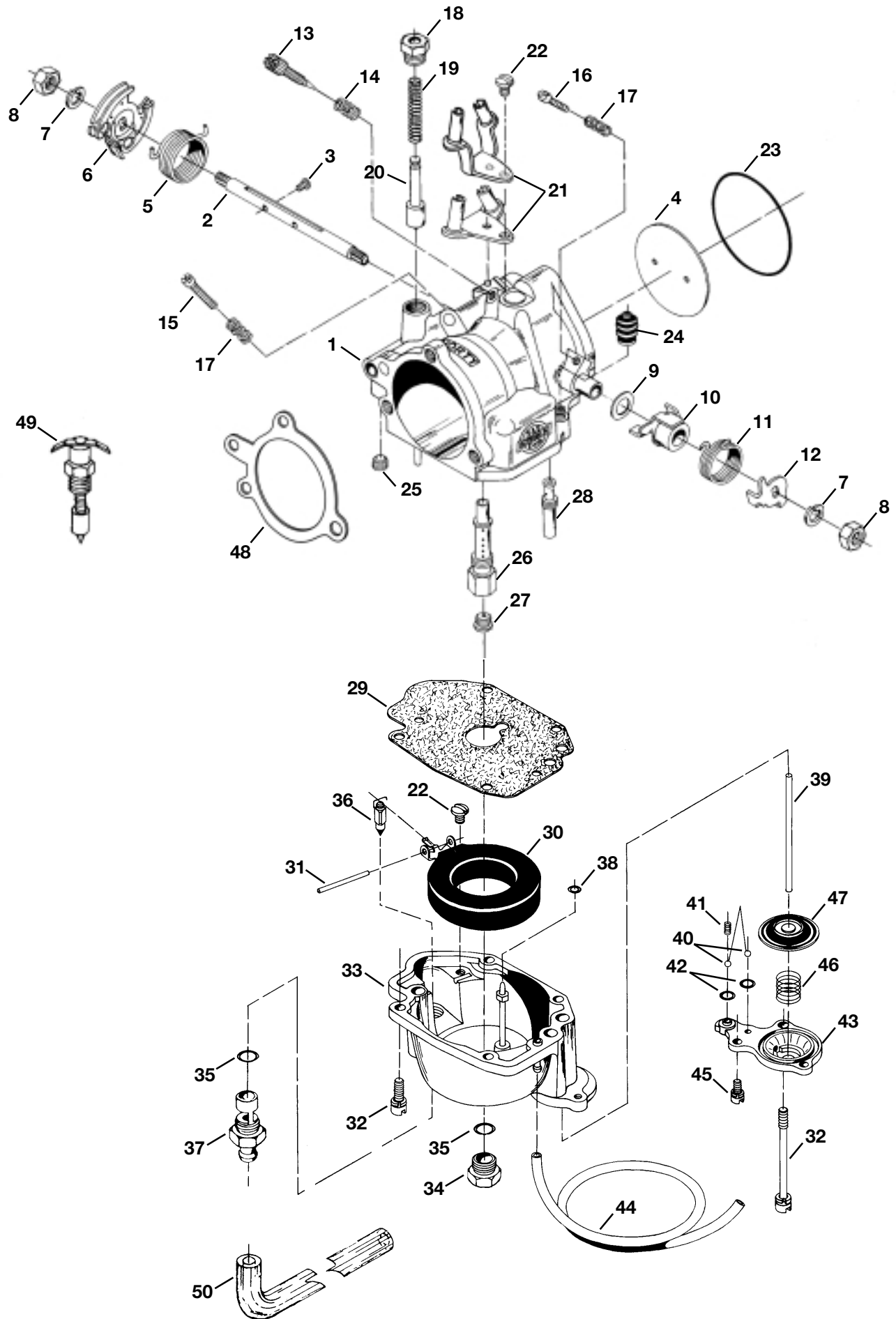

Replacement Parts for Super E & G Air Cleaners for Big Twins and Sportsters. *(Buell style air cleaners are listed separately.)*

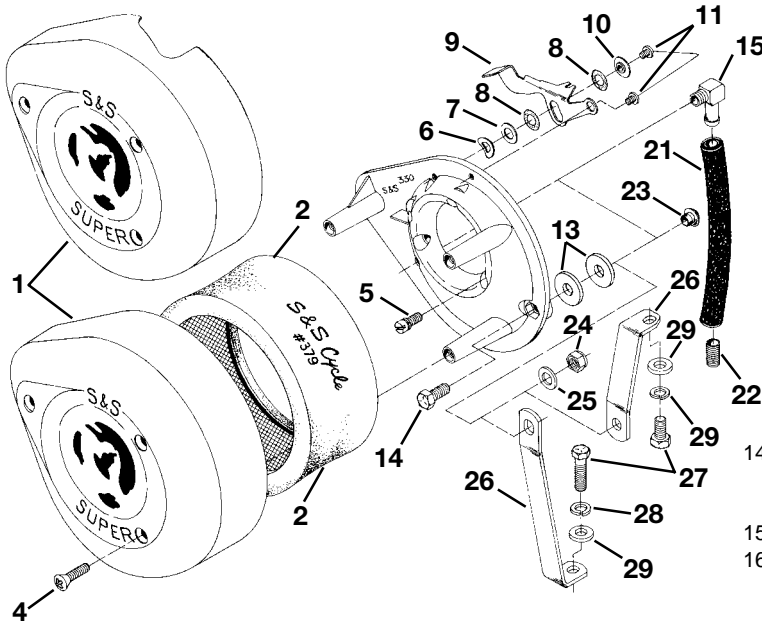

Pre V² Style #17-0400, #17-0440 (Notched)

- 1. Air cleaner cover
All (Excluding Shovel w/5 gallon tanks & cylinders +.075") #17-0378
Shovel w/5 gallon tanks & cylinders +.075" #17-0372
- 2. Element #17-0376
- 3. Backplate
All pre V² #17-0330
V² FL 1984-'92 & XL 1986-'90 #17-0380
V² FL 1993-up, V² XL 1991-up and Twin Cam 1999-up #17-0336
- 4. Cover screw #50-0072
- 5. Backplate screw #50-0075
- 6. Fast idle friction washer #50-7035
- 7. Fast idle steel washer #50-7037
- 8. Fast idle nylon washer #50-7036
- 9. Fast idle lever #17-0329
- 10. Fast idle brass washer #50-7007
- 11. Fast idle lever screw #50-0041
- 12. Shim kit
V² FL 1984-'92 & XL 1986-'90
(Includes 2 each 5/16" x .020", 5/16" x .030", 5/16" x .040", 5/16" x .100" and
4 each 5/16" x .125") #17-0314
FL 1993-up, XL 1991-up and Twin Cam 1999-up
(Includes 2 each 1/2" x .020", 1/2" x .030", 1/2" x .040", 1/2" x .100", and
4 each 1/2" x .125") #17-0464
- 13. Shim
V² FL 1984-'92 & V² XL 1986-'90
5/16" x .020" #50-7038
5/16" x .030" #50-7039
5/16" x .040" #50-7040
5/16" x .100" #50-7041
5/16" x .125" #50-7042
(Use on pre V²s when insulator block is installed.)
V² FL 1993-up (Before 2-1-01 - now obsolete.)
V² XL 1991-up (Before 6-15-01 - now obsolete.)
1/2" x .020" #50-7085
1/2" x .030" #50-7086
1/2" x .040" #50-7087
1/2" x .100" #50-7089
1/2" x .125" #50-7090

Shim - Continued

- V² FL 1993-up (After 2-1-01),
V² XL 1991-up (After 6-15-01) and Twin Cam 1999-up
5/16" x .025" #50-7113
5/16" x .050" #50-7114
5/16" x .075" #50-7115
- 14. Backplate mounting bolt - All pre V²
5/16" - 18 x 1" #50-0108
5/16" - 24 x 3/4" #50-0107
- 15. Elbow fitting #50-8110
- 16. Breather screw
FL V² 1993-up (Before 2-1-01, now obsolete.)
FL V² 1991-up (Before 6-15-01, now obsolete.)
All Buells
Standard Length #17-0338
1" longer (Use with 1" spacer block) #17-0343
- 17. Breather screw o-ring 5/8" O.D. #50-8032
- 18. Breather screw o-ring 1/2" O.D. #50-8006
- 19. Breather screw washer #50-7119
- 20. Breather fitting FL 1993-up, XL 1991-up, & Twin Cam #17-0337
- 21. Crankcase breather hose
FL 1984-1992 & XL 1986-1990 #17-0113
FL 1993-up FL, XL 1991-up, & Twin Cam #17-0339
- 22. Vent hose connector #50-8111
- 23. Backplate plug #50-8312
- 24. Locknut 5/16"-18 #50-5021
- 25. Flatwasher - 5/16" x 1/16" #50-7034
- 26. Support bracket
Shovel #17-0392
1957-'85 XL #17-0393

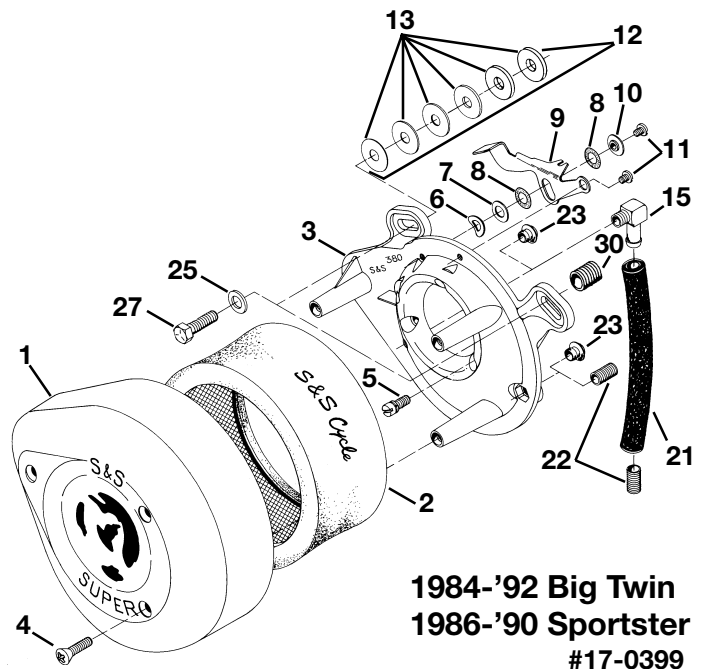

1984-'92 Big Twin 1986-'90 Sportster #17-0399

38. Mounting hardware packages - (Not shown.)

Pre V²

For #17-0400 or 17-0440 air cleaner **#17-0441**
 (Includes: 3 each - back plate screws, air cleaner cover screws; 2 each back plate plugs; 1 each - HHCS $\frac{5}{16}$ -18 x $1\frac{1}{4}$, HH locknut $\frac{5}{16}$ -18, lock washer $\frac{5}{16}$, flat washer $\frac{5}{16}$ x $\frac{1}{16}$, HHCS $\frac{5}{16}$ -18 x 1, flat washer $\frac{5}{16}$ x $\frac{1}{16}$, stepped fast idle washer, spring friction washer, HHCS $\frac{5}{16}$ -18 x $\frac{5}{8}$, flat washer .323 x $\frac{1}{32}$, fast idle lever.)

V² FL 1984-'92 & V² XL 1986-'90

For #17-0399 air cleaner **#17-0458**
 (Includes: 3 each back plate screws, air cleaner cover screws; 2 each - HHCS $\frac{5}{16}$ -18 x $1\frac{1}{4}$, back plate plugs, flat washer, 10-24 x $\frac{1}{4}$ pan head screws, $\frac{5}{16}$ x $\frac{1}{16}$, nylon washers; 1 each - elbow fitting $\frac{1}{8}$ x $\frac{3}{8}$ hose, close nipple $\frac{1}{8}$ -27 x $\frac{1}{4}$, shim kit, stepped fast idle washer, spring friction washer, flat washer .323 x $\frac{1}{32}$, fast idle lever.)

V² FL 1993 -up & V² XL 1991-up

For #17-0401 air cleaner **#17-0439**
 (Kits manufactured before 2-1-01 - now obsolete.)
 (Includes: 3 each - back plate screws, air cleaner cover screws; 2 each - back plate plugs, flat washers, 10-24 x $\frac{1}{4}$ pan head screws, $\frac{5}{16}$ x $\frac{1}{16}$, nylon washers, breather screws, back plate mount washers, breather fittings, o-rings $\frac{1}{2}$ " ID, o-rings $\frac{3}{8}$ " ID; 1 each - flat washer $\frac{5}{16}$ x $\frac{1}{8}$, HHCS $\frac{5}{16}$ -18 x 1, flat washer $\frac{5}{16}$ x $\frac{1}{16}$, stepped fast idle washer, spring friction washer, flat washer .323 x $\frac{1}{32}$, fast idle lever, breather hose, shim kit, hose clamp.)
 Mounting hardware packages - Continued
 (Not shown, kit contents by line drawing key number.)

V² FL 1993 -up & V² XL 1991-up

For #17-0404 air cleaner **#17-0436**
 (Includes: 3 each - back plate screws, air cleaner cover screws; 2 each - back plate plugs, flat washers, 10-24 x $\frac{1}{4}$ pan head screws, $\frac{5}{16}$ x $\frac{1}{16}$, nylon washers, breather screws, breather fittings; 1 each - flat washer $\frac{5}{16}$ x $\frac{1}{16}$ stepped fast idle washer, spring friction washer, flat washer .323 x $\frac{1}{32}$, fast idle lever, breather hose, shim kit, hose clamp.)

Twin Cam 1999-up

For 17-0403 air cleaner **#17-0437**
 (Includes: 3 each - back plate screws, air cleaner cover screws; 2 each - back plate plugs, flat washers, 10-24 x $\frac{1}{4}$ pan head screws, $\frac{5}{16}$ x $\frac{1}{16}$, nylon washers, breather screws, breather fittings; 1 each - flat washer $\frac{5}{16}$ x $\frac{1}{16}$, stepped fast idle washer, spring friction washer, flat washer .323 x $\frac{1}{32}$, fast idle lever, breather hose, shim kit, hose clamp.)

- 27. Mounting bracket bolt
 Shovel - $\frac{5}{16}$ -18 x $\frac{5}{8}$ " **#50-0106**
 FL 1984-'92 & 1957-'90 XL - $\frac{5}{16}$ -18 x $1\frac{1}{4}$ " **#50-0110**
- 28. Lockwasher - $\frac{5}{16}$ " **#50-7032**
- 29. Flatwasher - $\frac{5}{16}$ " x $\frac{1}{8}$ " **#50-7033**
- 30. Thread insert $\frac{1}{2}$ -13 to $\frac{5}{16}$ -18 **#50-8151**
- 31. Screw, air cleaner to head **#17-0346**
- 32. Breather screw
 FL V²'s 1993-up (After 2-1-01) and 1991-up (After 6-15-01) **#17-0347**
 Twin Cams 1999-up **#17-0345**
- 33. Outer breather screw seal $\frac{1}{2}$ " ID **#50-7055**
- 34. Inner breather screw Seal
 V² $\frac{1}{2}$ " ID (After 2-1-01) **#50-7055**
 Twin Cam $\frac{3}{8}$ " ID **#50-7054**
- 35. Wire tie (Not shown) **#50-8003**
- 36. Hose clamp (Not shown) **#50-8002**
- 37. Air cleaner kits
 (All kits include backplate, chrome cover, filter element, and hardware kit)
- All pre V² **#17-0400**
- All Shovel w/5 gallon tanks & cylinders .075" longer than stock ... **#17-0440**
- V² FL 1984-'92 & XL 1986-'90 **#17-0399**
- FL 1993-up (Before 2-1-01) and XL 1991-up (Before 6-15-01) (Now obsolete) **#17-0401**
- FL 1993-up (After 2-1-01), XL 1991-up (After 6-15-01) **#17-0404**
- Twin Cam 1999-up **#17-0403**

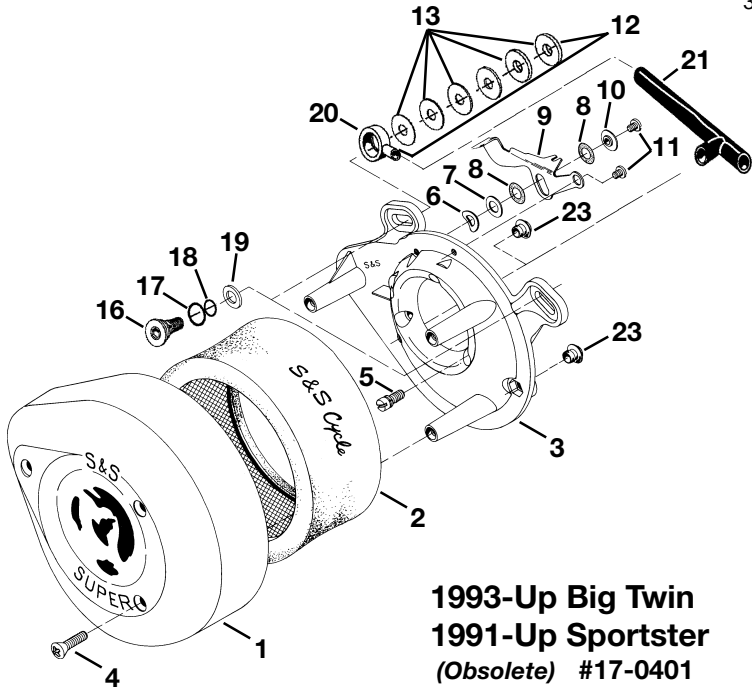

**1993-Up Big Twin
 1991-Up Sportster
 (Obsolete) #17-0401**

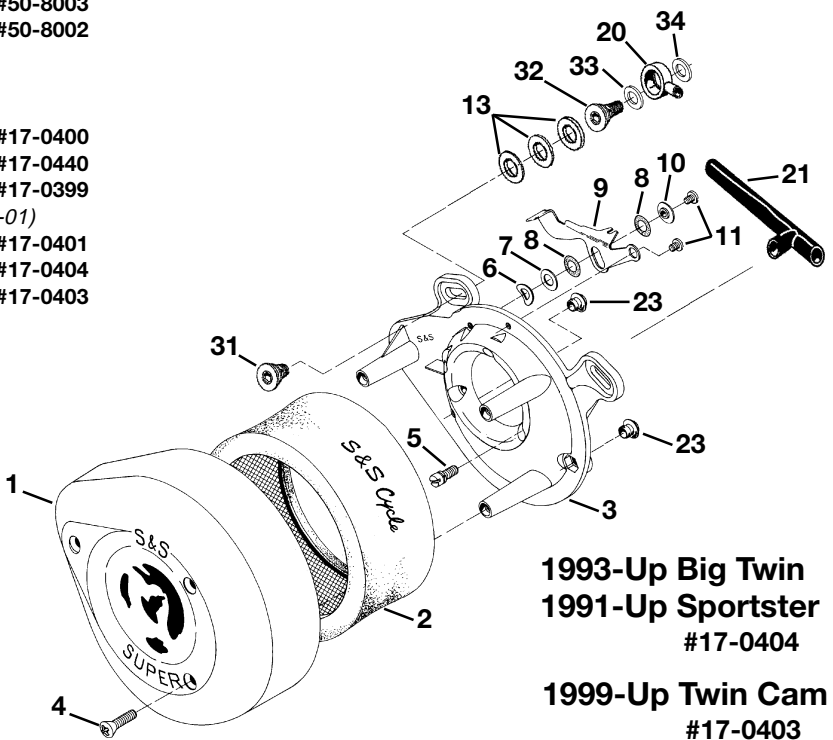

**1993-Up Big Twin
 1991-Up Sportster
 #17-0404**

**1999-Up Twin Cam
 #17-0403**

Replacement Parts for Super E & G Air Cleaners for Buells

- 1. Air cleaner cover 17-0078
- 2. Air cleaner element 17-0079
- 3. Air cleaner backing plate 17-0000
- 4. Air cleaner cover screw 50-0072
- 5. Air cleaner backplate screw 50-0073
- 6. Cap screw, breather & air cleaner mount 17-0338
- 7. Shim, .620" ID x .800" OD x .185" 50-7120
- 8. O-ring ½" ID x ⅝" OD x ⅛" CS 50-8032
- 9. O-ring ⅜" ID x 1/2" OD x ⅛" CS 50-8006
- 10. Fitting, breather, 17-0337
- 11. Shim kit, air cleaner back plate 17-0464
 Contains:
 - 2 each Shim ½" x 1" x .018 50-7085
 - 2 each Shim ½" x 1" x .030 50-7086
 - 2 each Shim ½" x 1" x .048 50-7087
 - 2 each Shim ½" x 1" x .105 50-7089
 - 4 each Shim ½" x 1" x .125 50-7090
- 12. Washer, friction, spring 50-7035
- 13. Washer, flat .323 x ⅝" x ⅛" 50-7037
- 14. Washer, flat, nylon .323 x ⅝" x .020 50-7036
- 15. Lever, fast idle, 17-0327
- 16. Washer, flat w/step, brass 50-7007
- 17. Screw, slotted, PH, 10-24 x ¼" 50-0041
- 18. Screw, hex head, cap, ¼"-28 x 7/8 50-0074
- 19. Washer, flat, ¼" x ⅝" x ⅛" 50-7021
- 20. Locknut - ¼-28 (HD #7683) 50-5010

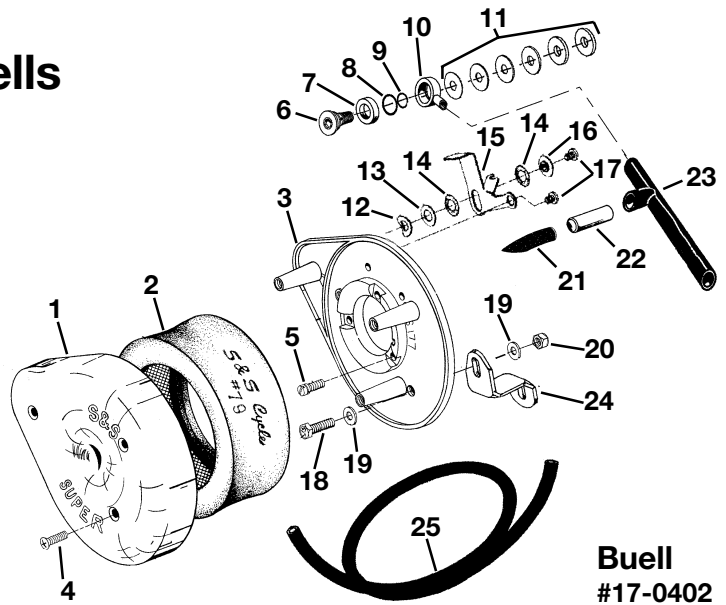

- 21. Hose, breather vent 17-0365
- 22. Fitting, hose, Buell A/C 50-8121
- 23. Hose, breather 17-0339
- 24. Bracket, carb support, A/C 17-0309
- 25. Tubing, rubber - ⅜" x ⅝" 19-0169

Replacement Parts for Super E and G Air Horns

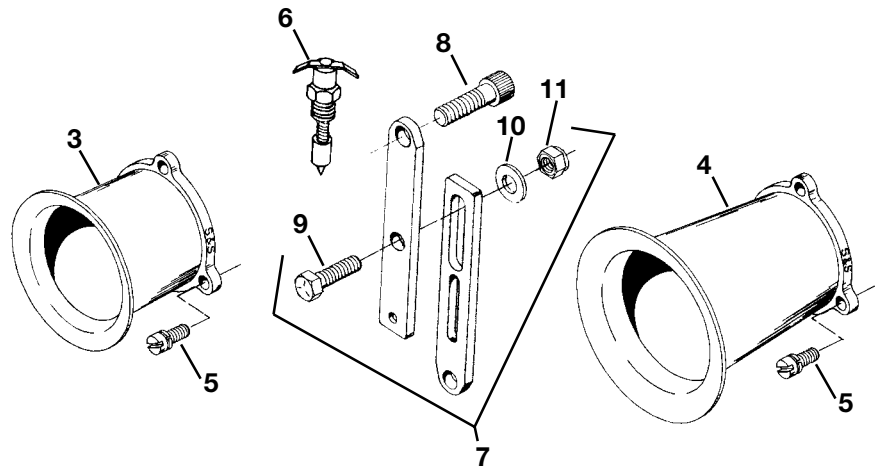

- 1. 2½" Air horn conversion kit **#17-0484**
 (Includes 1 each #16-0063, #11-2084, #16-0105, #17-0331, #16-0471.)
- 2. 4" Air horn conversion kit #17-0485
 (Includes 1 each #16-0063, #11-2084, #16-0105, #17-0333, #16-0471.)
- 3. 2½" Air horn assembly #17-0331
 (Includes 1 each air horn, 3 each #17-0391.)
- 4. 4" Air horn assembly #17-0333
 (Includes 1 each air horn, 3 each #17-0391.)
- 5. Air horn mounting screw #50-0075
- 6. Enrichment device #11-2084
 Used in place of standard fast idle mechanism if starting device is required when air horn is used.
- 7. Carb mounting bracket assembly #16-0471
 (Includes 1 each 2-piece bracket #17-0104, #17-0245, #17-0321.)
- 8. Manifold bolts
 ⅜ -16 x 1¼" #50-0162
 (Use in bottom hole with #16-0471 bracket without insulator block.)
 ⅜ -16 x 1⅝" #50-0163
 (Use in bottom hole with #16-0471 bracket with insulator block.)
- 9. Support bracket bolt - ⅜ -18 x 1" #50-0108
- 10. Flatwasher - ⅜" x ⅛" #50-7034
- 11. Locknut - ⅜ -18 (Use with #16-0471.) #50-5021

IMPORTANT NOTE - When an air horn is used on a Super E or G, a #16-0471 bracket which connects the center crankcase stud to the bottom carburetor manifold mounting screw must be used. This style bracket is also recommended for those applications where the cylinder heads have had the intake ports raised, causing misalignment problems with the normal carburetor mounting hardware. These engines are unusual situations and are handled on a special order basis.